

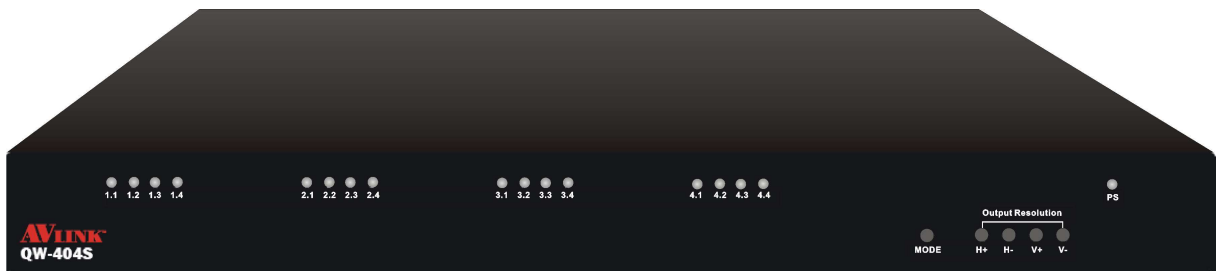

User Manual

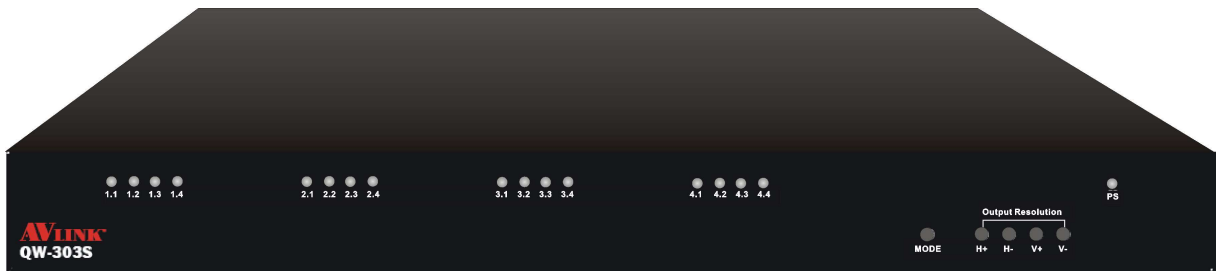
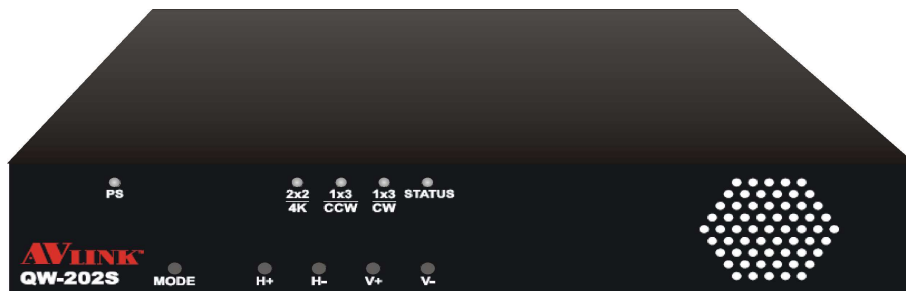

Crescent Walls

2x2 / 3x3 / 4x4

V.2016QWSeries.00

COPYRIGHT AND TRADEMARKS

All rights reserved by C&C TECHNIC TAIWAN CO., LTD. No part of this document may be reproduced in any form or by any means without written permission from the product manufacturer. Changes are periodically made to the information in this document. They will be incorporated in subsequent editions. The product manufacturer may make improvements and /or changes in the product described in this document at any time.

All the registered trademarks referred to this manual are belonging to their respective companies.

BEFORE YOU BEGIN

- Follow all instructions marked on the device during using.
- Provide proper ventilation and air circulation and do not use near water.
- It is better to keep it in a dry environment.
- Place the device on a stable surface (example cart, stand, table, etc.).
- The system should be installed indoor only. Install either on a sturdy rack or desk in a well-ventilated place.
- Make sure the rack is level and stable before extending a device from the rack if necessary.
- Make sure all equipments installed on the rack including power strips and other electrical connectors are properly grounded.
- Only use the power cord supported with the device.
- Do not use liquid or aerosol cleaners to clean the device.
- Always unplug the power to the device before cleaning.
- Unplug the power cord during lightning or after a prolonged period of non-use to avoid damage to the equipment.
- Do not stand on any device while installing the device to the rack.
- Do not attempt to maintain the device by yourself, any faults, please contact your vendor.
- Save this manual properly for future reference.

TABLE OF CONTENTS

| | |
|--|----|
| Copyright and Trademarks..... | 1 |
| Before You Begin | 2 |
| Table of Contents..... | 3 |
| List of Figures..... | 5 |
| Chapter 1 Overview..... | 7 |
| 1.1 Introduction..... | 7 |
| 1.2 Packing..... | 8 |
| 1.3 Accessories (Optional)..... | 8 |
| 1.4 Applications | 8 |
| Chapter 2 Features | 9 |
| Chapter 3 Specifications..... | 10 |
| Chapter 4 Installation | 11 |
| Chapter 5 Front/Rear Panels..... | 12 |
| 5.1 Front Panel | 12 |
| 5.2 Rear Panel..... | 13 |
| 5.2.1 HDMI Output Connector | 15 |
| 5.2.2 Wiring Information for LAN Connector | 15 |
| Chapter 6 Connections | 16 |
| 6.1 Input Connection..... | 19 |
| 6.2 Output Connection | 19 |
| 6.2.1 HDBaseT Output Port..... | 20 |
| 6.2.2 Output Cable | 21 |
| 6.3 Power Connection | 22 |
| Chapter 7 Web Interface Configuration | 23 |
| 7.1 Setup | 24 |
| 7.1.1 Monitor Arrangements and Settings | 25 |
| 7.1.2 Mullion Adjustments | 28 |
| 7.1.3 Offset and Zoom Settings..... | 29 |
| 7.1.4 Color Settings..... | 29 |
| 7.2 Advance | 32 |
| 7.3 Administration..... | 33 |
| 7.3.1 Username | 33 |
| 7.3.2 Password | 33 |
| 7.3.3 Network | 34 |
| Chapter 8 Troubleshooting..... | 35 |
| Appendix A Extender (Optional)..... | 36 |
| Extender Connection | 36 |

CRESCENT WALLS - QW SERIES

| | |
|---|----|
| Appendix B Video Wall Configuration | 37 |
| 2x2 Mode | 38 |
| 3x3 Mode | 41 |
| 4x4 Mode | 41 |
| 1x3 CW Mode | 42 |
| 1x3 CCW Mode | 42 |
| Landscape 1x3 A/B/C Mode | 43 |
| 3x4 Mode A / 3x4 Mode B | 45 |
| 2x3 Mode A / 2x3 Mode B | 46 |
| 2x8 CW / 2x8 CCW | 47 |

LIST OF FIGURES

| | |
|---|----|
| Figure 1: QW Series (for QW-202S)..... | 7 |
| Figure 2: Mount QW Series on a Standard Bracket with 1U Rack-mount..... | 11 |
| Figure 3: Place the device on a sturdy surface..... | 11 |
| Figure 4: Mount the device in the rack..... | 11 |
| Figure 5: QW-202S (H) Front Panel..... | 12 |
| Figure 6: QW-303S (H) Front Panel..... | 12 |
| Figure 7: QW-404S (H) Front Panel..... | 12 |
| Figure 8: QW-202S Rear Panel..... | 13 |
| Figure 9: QW-202H Rear Panel..... | 13 |
| Figure 10: QW-303S Rear Panel..... | 13 |
| Figure 11: QW-303H Rear Panel..... | 13 |
| Figure 12: QW-404S Rear Panel..... | 13 |
| Figure 13: QW-404H Rear Panel..... | 13 |
| Figure 14: HDMI Output Connector..... | 15 |
| Figure 15: LAN Connector..... | 15 |
| Figure 16: QW-202S Connections..... | 16 |
| Figure 17: QW-202H Connections..... | 16 |
| Figure 18: QW-303S Connections..... | 17 |
| Figure 19: QW-303H Connections..... | 17 |
| Figure 20: QW-404S Connections..... | 18 |
| Figure 21: QW-404H Connections..... | 18 |
| Figure 22: Input Connection..... | 19 |
| Figure 23: Output Connection with HDMI Interface..... | 19 |
| Figure 24: Output Connection with RJ-45 Interface..... | 20 |
| Figure 25: LAN (HDBT) Port Pin Definition..... | 20 |
| Figure 26: Output Cable..... | 21 |
| Figure 27: Power Connection..... | 22 |
| Figure 28: Web Control Address..... | 23 |
| Figure 29: Web Control - Login..... | 23 |
| Figure 30: Web Control - Setup..... | 24 |
| Figure 31: Wall Board..... | 25 |
| Figure 32: Wall Modes..... | 26 |
| Figure 33: Output Resolution..... | 27 |
| Figure 34: Output Modes..... | 27 |
| Figure 35: Mullion Adjustment..... | 28 |
| Figure 36: Mullion Adjustment Compensation..... | 28 |

CRESCENT WALLS - QW SERIES

| | |
|---|----|
| Figure 37: Color Settings | 29 |
| Figure 38: Output Port Color Temperature..... | 30 |
| Figure 39: Common Color Temperature | 30 |
| Figure 40: Color Temperature Bar | 30 |
| Figure 41: RGB Adjustment..... | 31 |
| Figure 42: Web Control - Advance | 32 |
| Figure 43: Web Control - Administration | 33 |
| Figure 44: Extender | 36 |
| Figure 45: Extender Connection | 36 |
| Figure 46: Wall Modes List for QW-404x..... | 37 |
| Figure 47: 2x2 Mode Status 1 | 38 |
| Figure 48: 2x2 Mode Status 2 | 39 |
| Figure 49: 2x2 Mode Status 3 | 40 |
| Figure 50: 3x3 Mode..... | 41 |
| Figure 51: 4x4 Mode..... | 41 |
| Figure 52: 1x3 CW Mode | 42 |
| Figure 53: 1x3 CCW Mode | 42 |
| Figure 54: Landscape 1x3 A Mode..... | 43 |
| Figure 55: Landscape 1x3 B Mode | 43 |
| Figure 56: Landscape 1x3 C Mode | 44 |
| Figure 57: 3x4 Mode A | 45 |
| Figure 58: 3x4 Mode B..... | 45 |
| Figure 59: 2x3 Mode A | 46 |
| Figure 60: 2x3 Mode B..... | 46 |
| Figure 61: 2X8 CW Mode | 47 |
| Figure 62: 2X8 CCW Mode | 47 |

CHAPTER 1 OVERVIEW

1.1 Introduction

The crescent walls is a video wall consists of multiples monitors (2x2 / 3x3 / 4x4) lied together contiguously or overlapped in order to form one large screen. Use typical display technologies and mullion compensation with seamless output feature.

For the video display orientation configuration, the crescent walls allow you to configure the video with landscape mode – a widescreen landscape display mode. The output picture will adjust the aspect ratio to available display size automatically. The picture will not be deformed due to a rotation.

Moreover, while color temperature dramatically affects the picture qualities of an LCD monitor. User can simply use the default values to restore the picture basic quality. A good understanding of the meaning of color temperature will enable better adjustments of LCD monitor picture quality.

Through the HDBT (QW-202S / 303S / 404S) or HDMI (QW-202H / 303H / 404H) interfaces you can optional select output transmission mode featuring a high resolution and low energy consumption. Typical application areas of the crescent walls include information displays, digital advertisings, meeting rooms and so on.

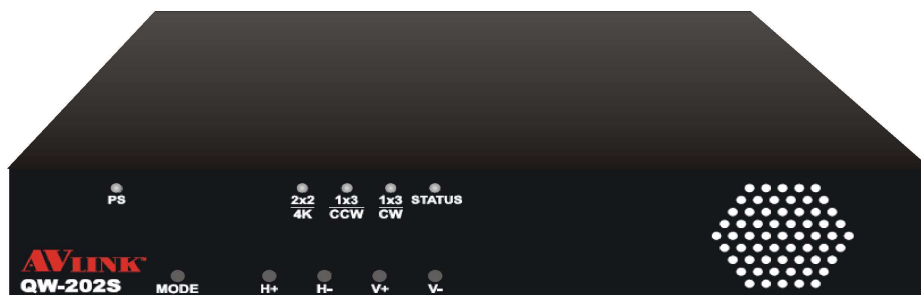







Figure 1: QW Series (for QW-202S)

1.2 Packing

| | |
|---|---------------------------------------|
|  | QW-202S (H) / 303S (H) / 404S (H) x 1 |
|  | Power Cord x 1 |
|  | CD User Manual x 1 |

1.3 Accessories (Optional)

| | |
|---|---------------------------|
|  | HDMI Remote Extender |
|  | Rack-Mount Bracket x 2 |
|  | Screws (for Brackets) x 6 |

1.4 Applications

Video Walls can be used to display information for:

- Public and Emergency Services
- Intelligent Traffic Systems
- Surveillance and Security
- Telecommunications
- Power and Utilities
- Data Monitoring
- Broadcast
- Defense
- Energy

CHAPTER 2 FEATURES

- Crescent Video Wall can be configured as 2x2 / 3x3 / 4x4
- Mullian compensation
- Color temperature adjustments
- Can be configured landscape mode to be used as video walls (with mullion compensation).
- Supports 1 HDMI connector for output display identical image on local side
- Option HDBT or HDMI output
 - Supports 1 HDMI connector for input and 4/12/16 RJ-45 connectors for HDBaseT output interfaces
 - Supports 1 HDMI connector for input and 4/12/16 HDMI connectors for HDMI output interfaces
- HDBaseT Output supports the long-distance transmission via a 70m Cat.5e cable
- Supports HDMI Remote Extender (Optional)
- Supports resolution up to 1080P for each Crescent Video Wall
- Internal universal power supply
- 1U rack design.

CHAPTER 3 SPECIFICATIONS

| Hardware | |
|---|---|
| Input Connector | HDMI Type A Female: <ul style="list-style-type: none"> - QW-202S (H) x1 - QW-303S (H) x 3 - QW-404S (H) x 4 |
| Output Connector (Local) | HDMI Type A Female (Local Video Output): <ul style="list-style-type: none"> - QW-202S (H) x1 - QW-303S (H) x 3 - QW-404S (H) x 4 |
| Output Connector (Remote) | RJ-45 Connector: <ul style="list-style-type: none"> - QW-202S: RJ-45 x 4 - QW-303S: RJ-45 x 12 - QW-404S: RJ-45 x 16 HDMI Connector: <ul style="list-style-type: none"> - QW-202H: HDMI x 4 - QW-303H: HDMI x 12 - QW-404H: HDMI x 16 |
| IP Port | RJ-45 IP Port x 1 |
| Power | 100VAC~240VAC, 50/60Hz, internal |
| LED Indicator (Standard HDMI Signal) | LED indicator specified for the power status x 1 LED indicators specified for the signal status: <ul style="list-style-type: none"> - QW-202S (H) x 4 - QW-303S (H) x 12 - QW-404S (H) x 16 |
| Housing | Metal |
| Mounting | Rack mountable (1U-rack-mount kit) |
| Weight | QW-202S (H): 3.9Kg QW-303S (H): 6.8Kg QW-404S (H): 7.2Kg |
| Dimensions (LxWxH) | QW-202S (H): 254 * 485 * 44mm QW-303S (H): 446 * 540 * 44mm QW-404S (H): 446 * 540 * 44mm |
| Multimedia | |
| Max. Resolution | 1080P / 1366 x 768 for each Crescent Video Wall |
| Control Information | |
| HDMI Cable Distance | Local: 10 meters (Max.) / Remote: 10 meters (Max.) |
| Cat.5e Cable Distance | 70 meters (Max.) for QW-202S / 303S / 404S |

CHAPTER 4 INSTALLATION

QW Series has a black metallic housing. It can be placed on a sturdy desk directly or installed on a bracket. You can also use the rubber feet pasted on the bottom of the chassis to protect your device when you want to place the device on a working desk.

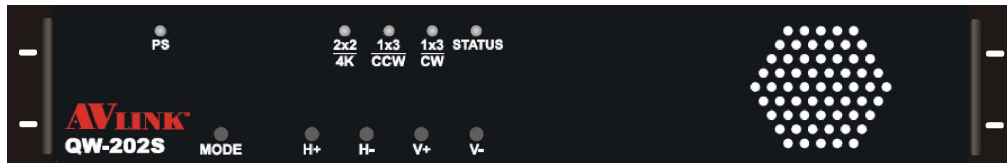

Figure 2: Mount QW Series on a Standard Bracket with 1U Rack-mount

Attach the rubber feet to the bottom of the device, Place the device on a sturdy, level surface that can support the weight.

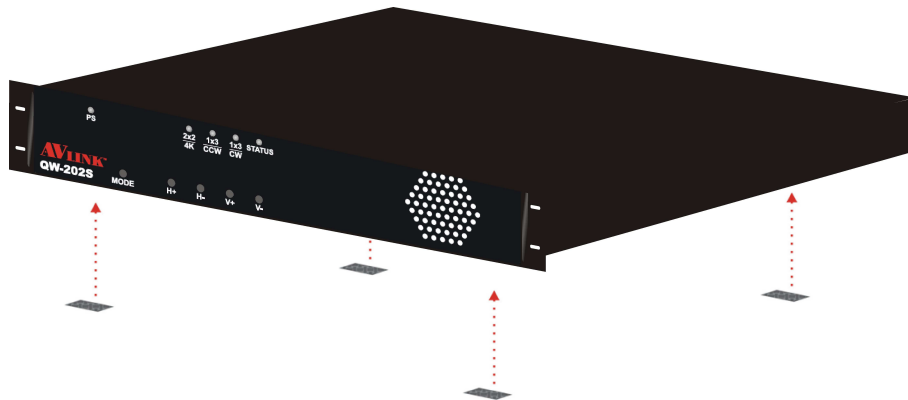

Figure 3: Place the device on a sturdy surface

Or use the screws provided with the rack and a screw driver to firmly tighten the device in the rack to prevent working lose due to vibration on the rack.

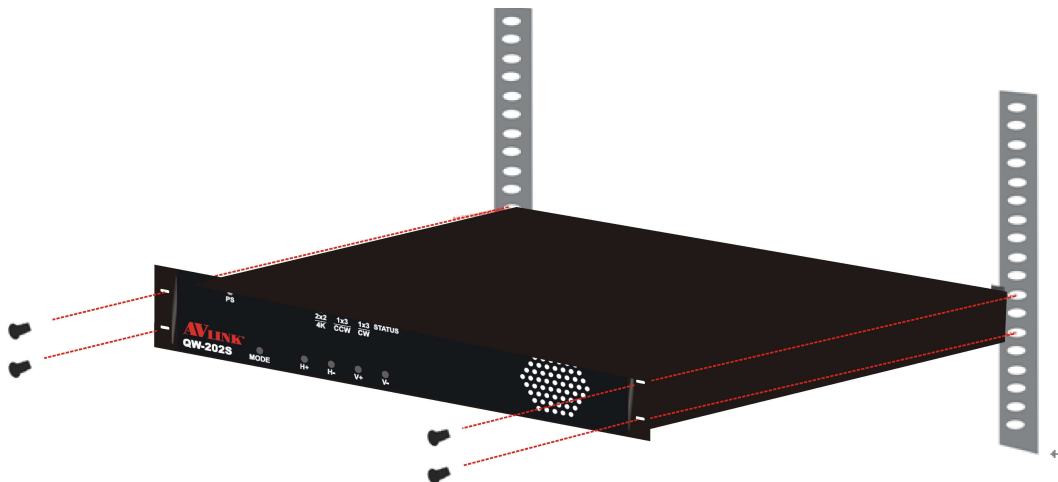

Figure 4: Mount the device in the rack

CHAPTER 5 FRONT/REAR PANELS

5.1 Front Panel

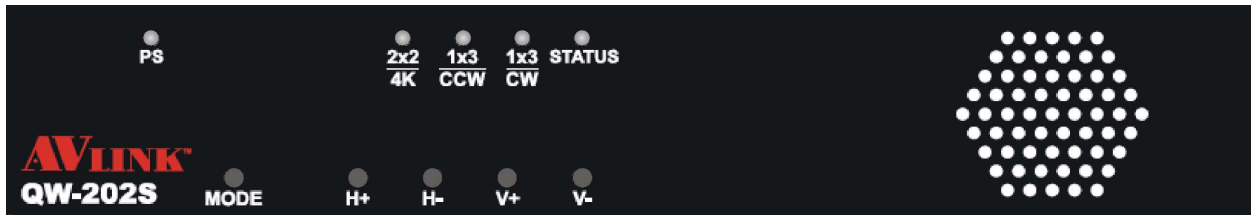

Figure 5: QW-202S (H) Front Panel

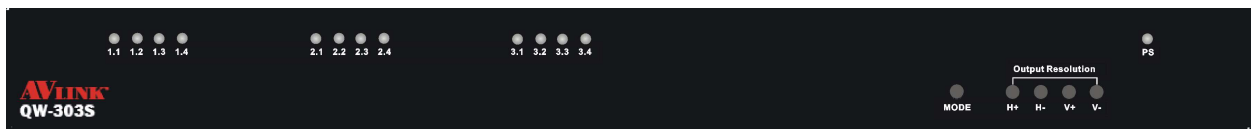

Figure 6: QW-303S (H) Front Panel

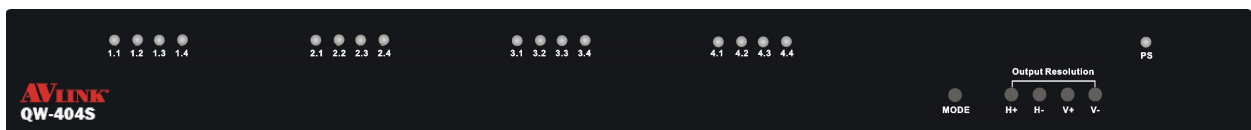

Figure 7: QW-404S (H) Front Panel

The QW Series support a clear LED indicator designed for the status of the power and four LED indicators designed for the signal status. Use the rotary knobs on the front panel that you can configure the QW Series without using any software interface.

- **MODE:** For QW-202S (H), you can use the **MODE** button to select the wall mode. For QW-303S (H) or QW-404S (H), you can press and hold the **MODE** button for reset feature.
- **H+ / H- / V+ / V-:** Use the rotary knobs labeled **H+**, **H-**, **V+** or **V-** on the front panel to adjust the Mullion compensation of the output image.
- **PS LED indicator:** Show you the power status. (Green = valid, Red = invalid)
- **2x2 4K / 1x3 CCW / 1x3 CW / STATUS LED indicators (for QW-202S (H) only):** Output signal status indicator. (Green = valid, Red = invalid)
- **1.1~3.4 or 4.4 LED indicators (for QW-303S (H) or QW-404S (H)):** Output signal status indicator. (Green = valid, Red = invalid)

5.2 Rear Panel

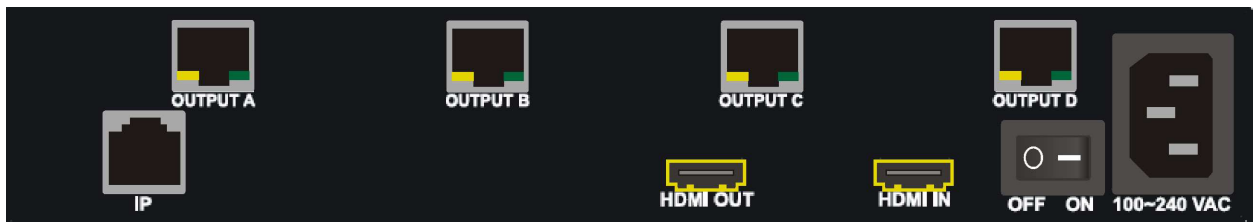

Figure 8: QW-202S Rear Panel

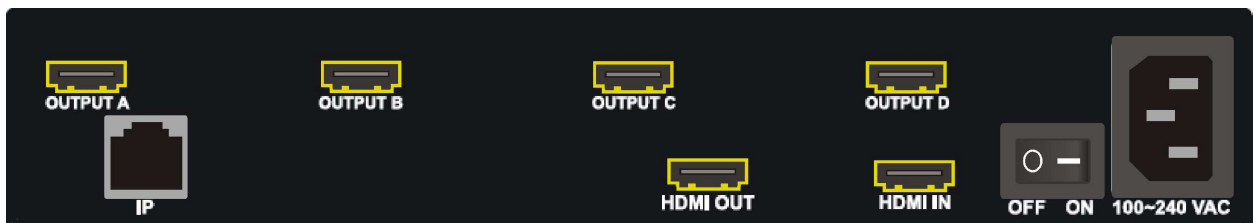

Figure 9: QW-202H Rear Panel



Figure 10: QW-303S Rear Panel

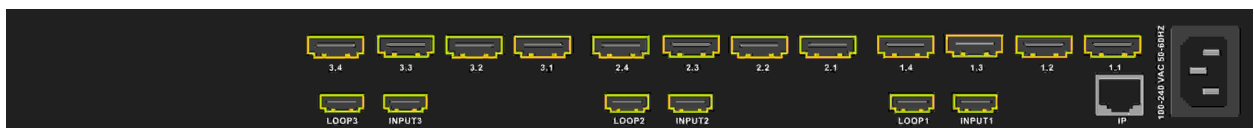

Figure 11: QW-303H Rear Panel



Figure 12: QW-404S Rear Panel



Figure 13: QW-404H Rear Panel

CRESCENT WALLS – QW SERIES

QW Series support up to 4/12/16 output jacks (RJ-45 for QW-202S / 303S / 404S) or (HDMI for QW-202H / QW-303H / QW-404H) on the rear panel, each female terminal separately form the output jacks. QW Series terminal channels numbered as OUTPUT x are for signals output. The input interface with “**HDMI IN**” jack supplies you to connect to different equipment including CD/DVD player, Blu-ray player, PS3 and so on. Another output interface with “**HDMI OUT**” jack allows you to connect to a local output device just as the projectors, video recorders, displays, multiplexers and so on.

- **Power port:** The Power Port is applicable for 100~240VAC, 50~60Hz connected to the outlet of power source. Refer to [6.3 Power Connection](#).
- **Local HDMI OUT (LOOP x) jack:** This is connected to the A/V or HDTVs.
- **HDMI IN (INPUT x) jack:** This is connected to the CD/DVD player, Blu-ray player, PS3, Video Camera, STB and so on.
- **Remote RJ-45 OUT Ports (OUTPUT x) for QW-202S/303S/404S only:** You can use the output jacks for over long connections via the extensible accessory devices. Refer to [Appendix A Extender \(Optional\)](#).
- **Remote HDMI OUT Ports (OUTPUT x) for QW-202H/303H/404H only:** You can use these output jacks located on the rear panel to transmit the signals to the output displays with a HDMI cable.
- **Power Switcher:** Switch the device on or off.
- **IP:** Connected to local PC with a RJ-45 Ethernet cable for software configuration.

5.2.1 HDMI Output Connector

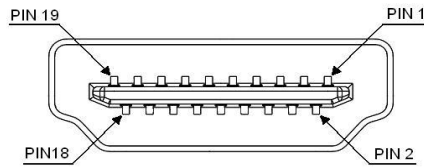

Figure 14: HDMI Output Connector

HDMI Type A Connector host assignment:

| Pin # | Signal | Pin # | Signal |
|-------|--------------------|-------|-------------------|
| 1 | TMDS Data 2+ | 11 | TMDS Clock Shield |
| 2 | TMDS Data 2 Shield | 12 | TMDS Clock - |
| 3 | TMDS Data 2- | 13 | NC |
| 4 | TMDS Data 1+ | 14 | NC |
| 5 | TMDS Data 1 Shield | 15 | DDC SCL |
| 6 | TMDS Data 1- | 16 | DDC SDA |
| 7 | TMDS Data 0+ | 17 | DDC/CEC Ground |
| 8 | TMDS Data 0 Shield | 18 | +5V Power |
| 9 | TMDS Data 0- | 19 | Hot Plug Detect |
| 10 | TMDS Clock+ | | |

5.2.2 Wiring Information for LAN Connector

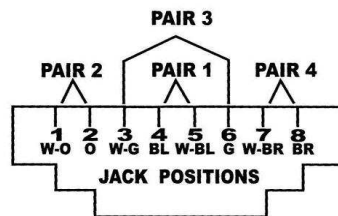

Figure 15: LAN Connector

| Conductor Identification | RJ-45 Pin Assignment | Color Code for Conductor |
|--------------------------|----------------------|--------------------------|
| Pair 1 | 5 | White-Blue |
| | 4 | Blue |
| Pair 2 | 1 | White-Orange |
| | 2 | Orange |
| Pair 3 | 3 | White-Green |
| | 6 | Green |
| Pair 4 | 7 | White-Brown |
| | 8 | Brown |

CHAPTER 6 CONNECTIONS

Before making the connections, make sure all devices are powered off. Refer to the illustrated connections below and also to the user manual of the device you are connecting to the QW Series.

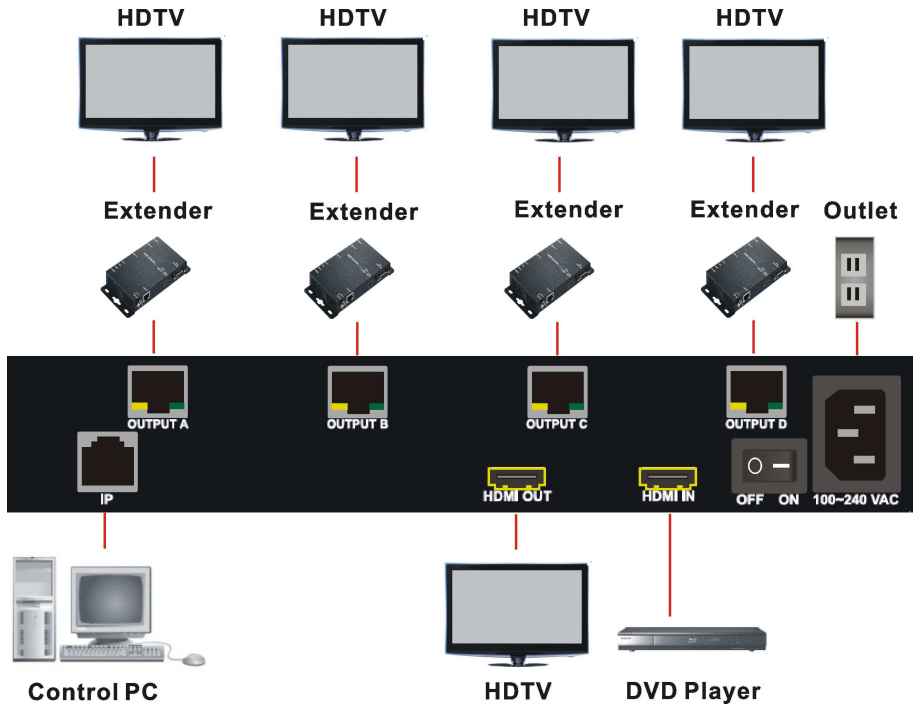

Figure 16: QW-202S Connections

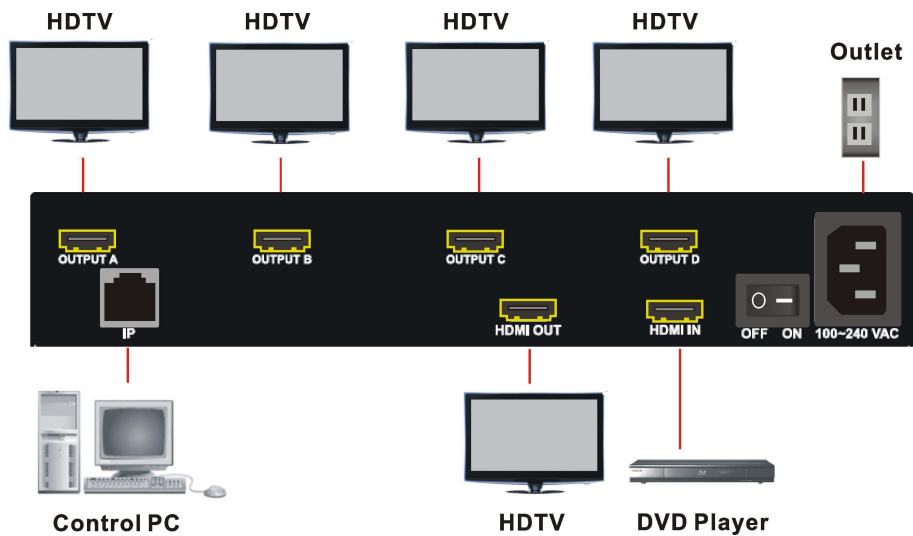

Figure 17: QW-202H Connections

CRESCENT WALLS - QW SERIES

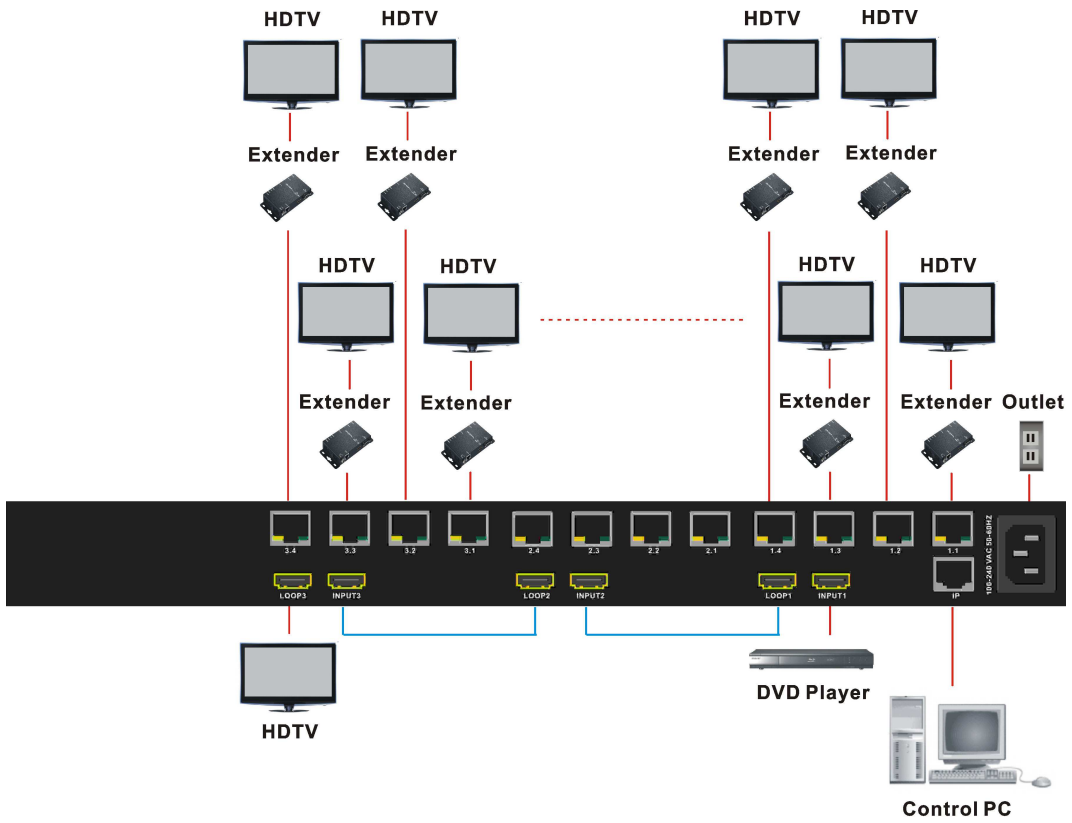

Figure 18: QW-303S Connections

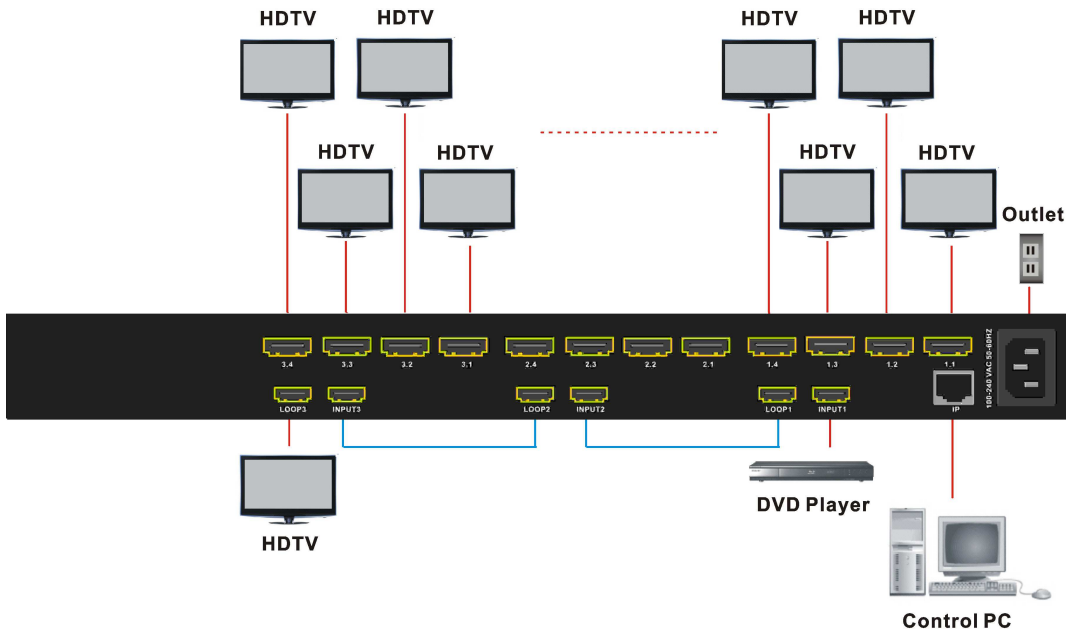

Figure 19: QW-303H Connections

CRESCENT WALLS - QW SERIES

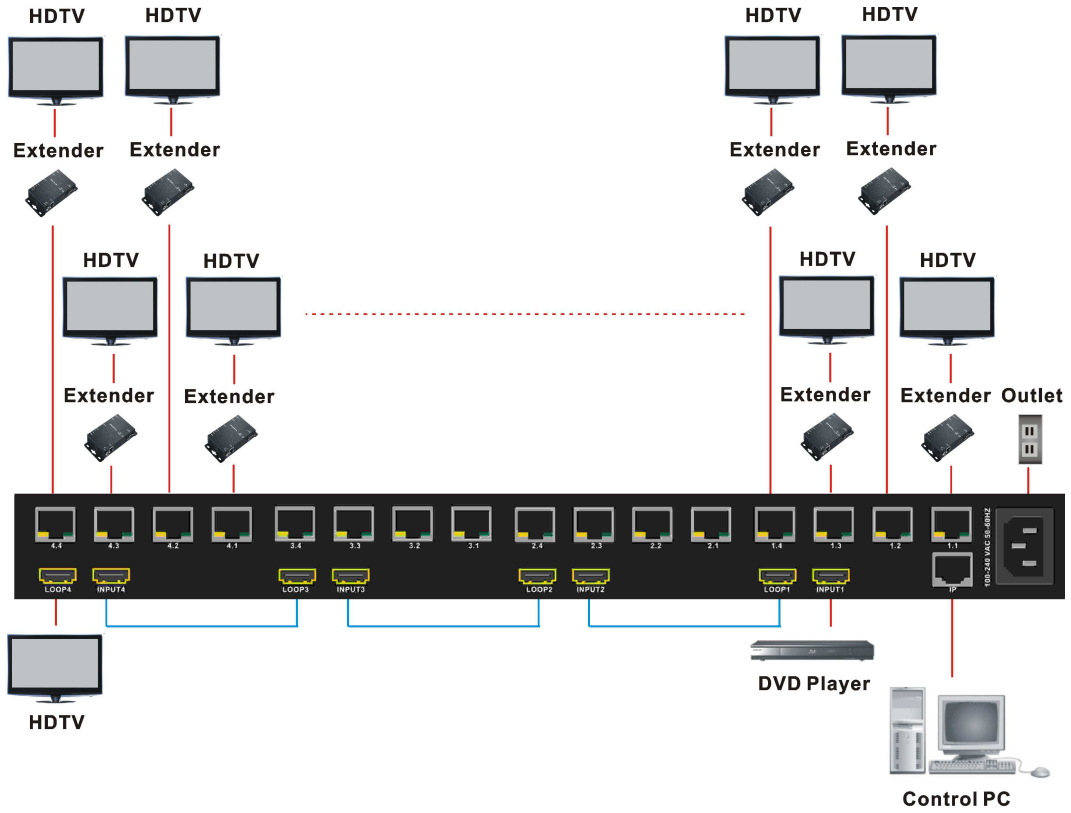

Figure 20: QW-404S Connections

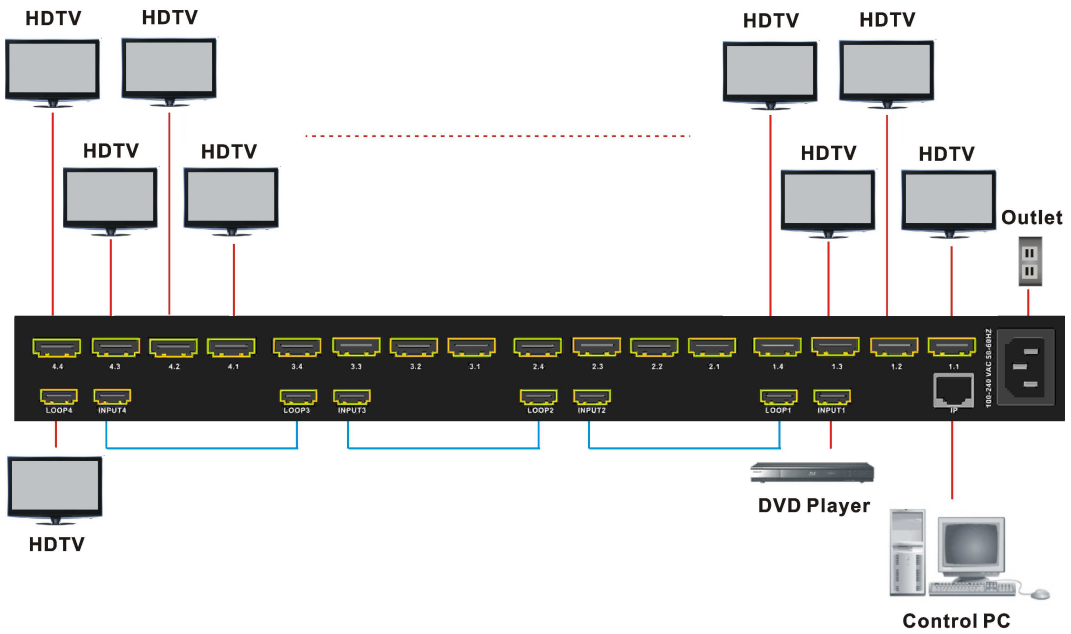

Figure 21: QW-404H Connections

6.1 Input Connection

Use the HDMI connecting cable to connect the Input serial jack (HDMI IN) to the HDMI jack of the Blu-ray/DVD player/graphics workstations/PC.

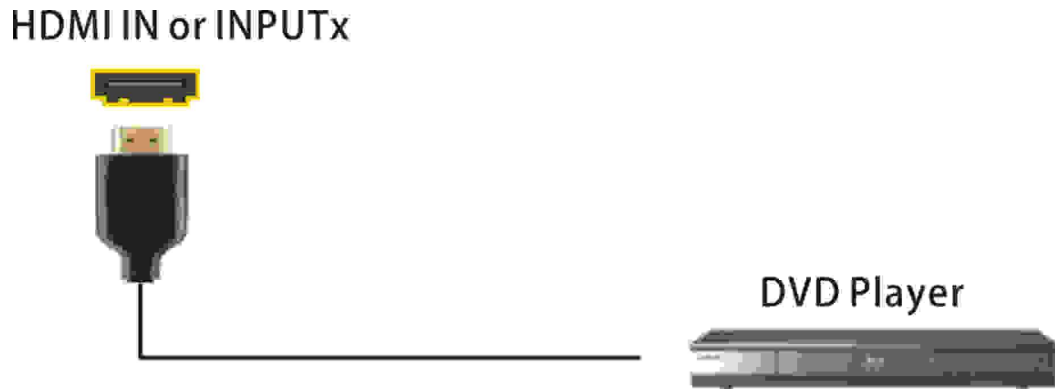

Figure 22: Input Connection

6.2 Output Connection

Use the HDMI cable to connect the output jacks on the rear panel to the input jack of the projector, video recorder, display, HD TV or multiplexer directly.

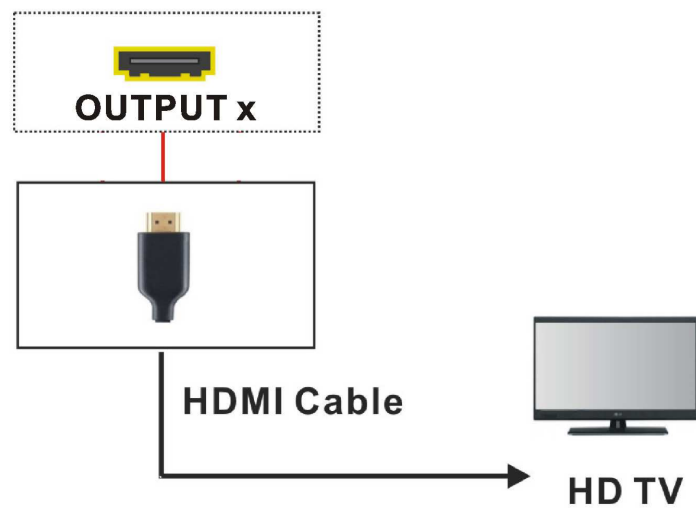

Figure 23: Output Connection with HDMI Interface

Or use the Cat.5e cable to connect the output RJ-45 jacks on the rear panel to the LINK jack of the Extender. Through the Extender, you can extend the transmission distance and over-long configuring the projector, video recorder, display or multiplexer to your Switcher.

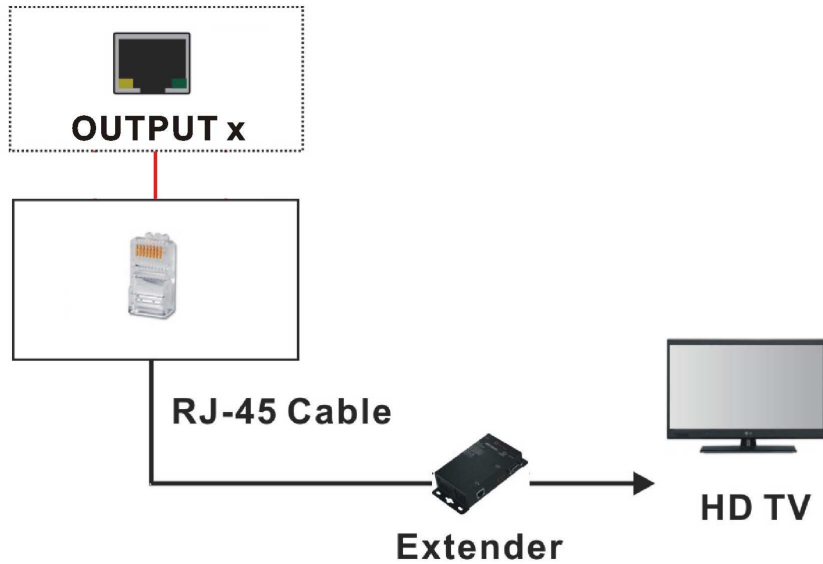

Figure 24: Output Connection with RJ-45 Interface

6.2.1 HDBaseT Output Port

QW-Series supports RJ-45 registered jacks using 8P8C modular connector, which specifies the physical male and female connectors as well as the pin assignments of the wires in a telephone cable. (A common LAN cable is available.)

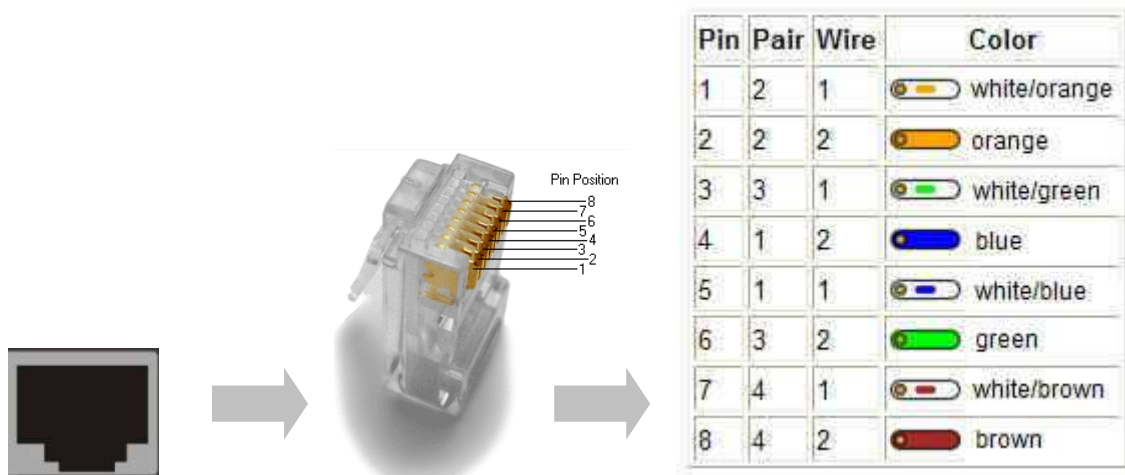

Figure 25: LAN (HDBT) Port Pin Definition

6.2.2 Output Cable

HDBaseT was designed to provide Full HD performance up to 70 meters of Cat.5e or superior cables. In a typical installation, the cable is stretched to its full length between the HDBaseT Transmitter device and the HDBaseT Receiver device. However sometimes, especially, in demonstrations or in a lab environment, the cable is rolled randomly in small turns for convenience. The randomly rolled UTP cable suffers additional signal impairments (compared to straight cable) and therefore the maximal operating reach might be reduced. When a Cat.5e cable is randomly rolled, it is recommended to limit its length to approximate 50 meters. Rolling a Cat.5e cable around a 70cm fixed diameter plastic drum has just a minor effect on the FEXT (Far End Cross Talk) when compared to a fully stretched cable.

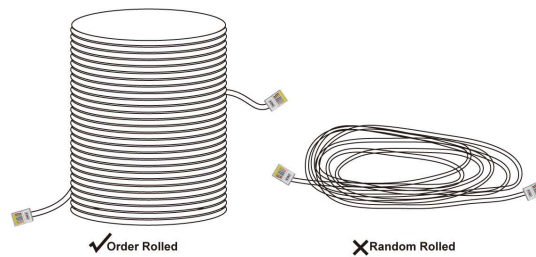

Figure 26: Output Cable

6.3 Power Connection

Use the included power cord to connect the power source from the power port on the rear panel of QW-Series to the outlet.

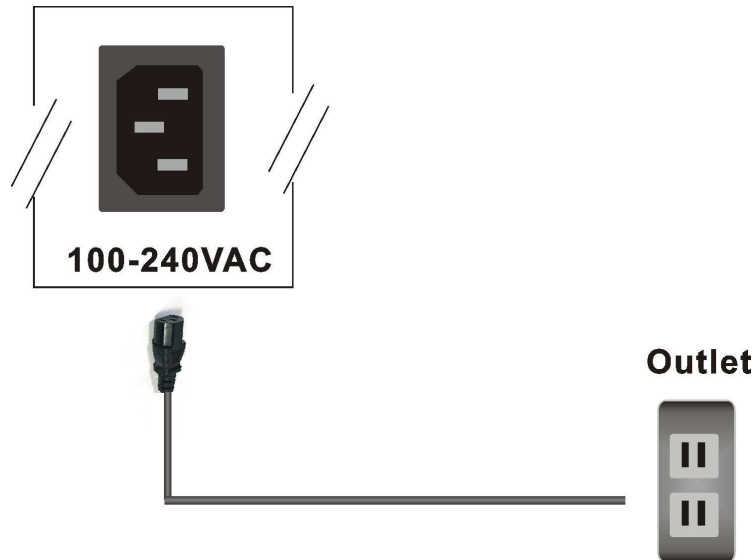

Figure 27: Power Connection

CHAPTER 7 WEB INTERFACE CONFIGURATION

Connect the “IP” port of the device to your computer or network using a standard Ethernet cable. If you connect directly to your computer, you may need to set your computer’s IP address to the same subnet as the device.

The default address is **192.168.1.151**. Open a web browser and type **192.168.1.151** in the URL address line. The login page will be displayed when the connection is successfully.

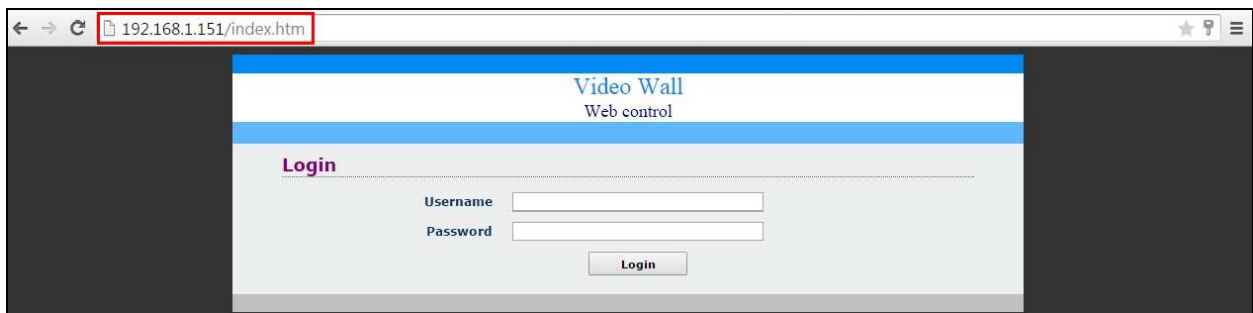

Figure 28: Web Control Address

The default username is “**admin**”, the default password is “**admin**”. The username and password are case sensitive.

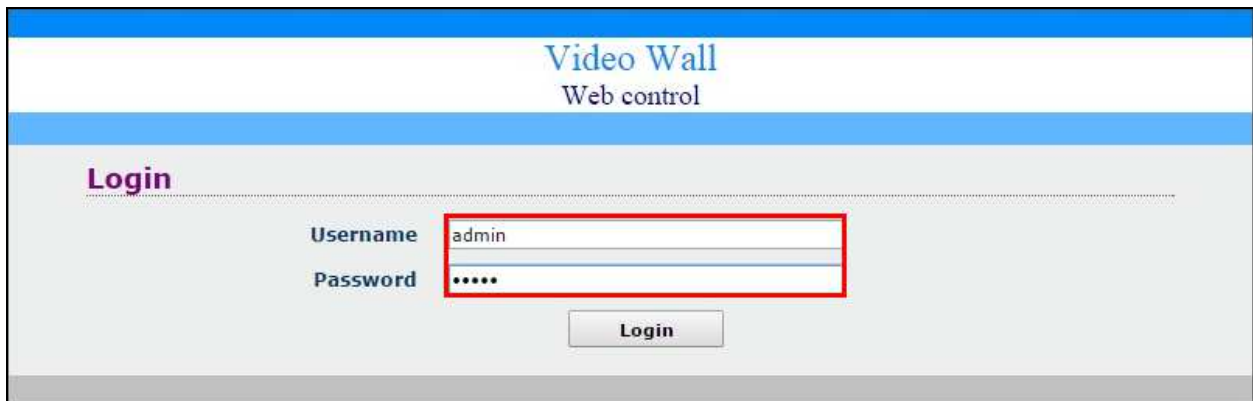

Figure 29: Web Control - Login

7.1 Setup

After you login to the built-in page, you will be able to access 3 tabs: **Setup**, **Advance** and **Administration**. Click the **Administration** tab.

The **Setup** tab page shows you the primary configurations.

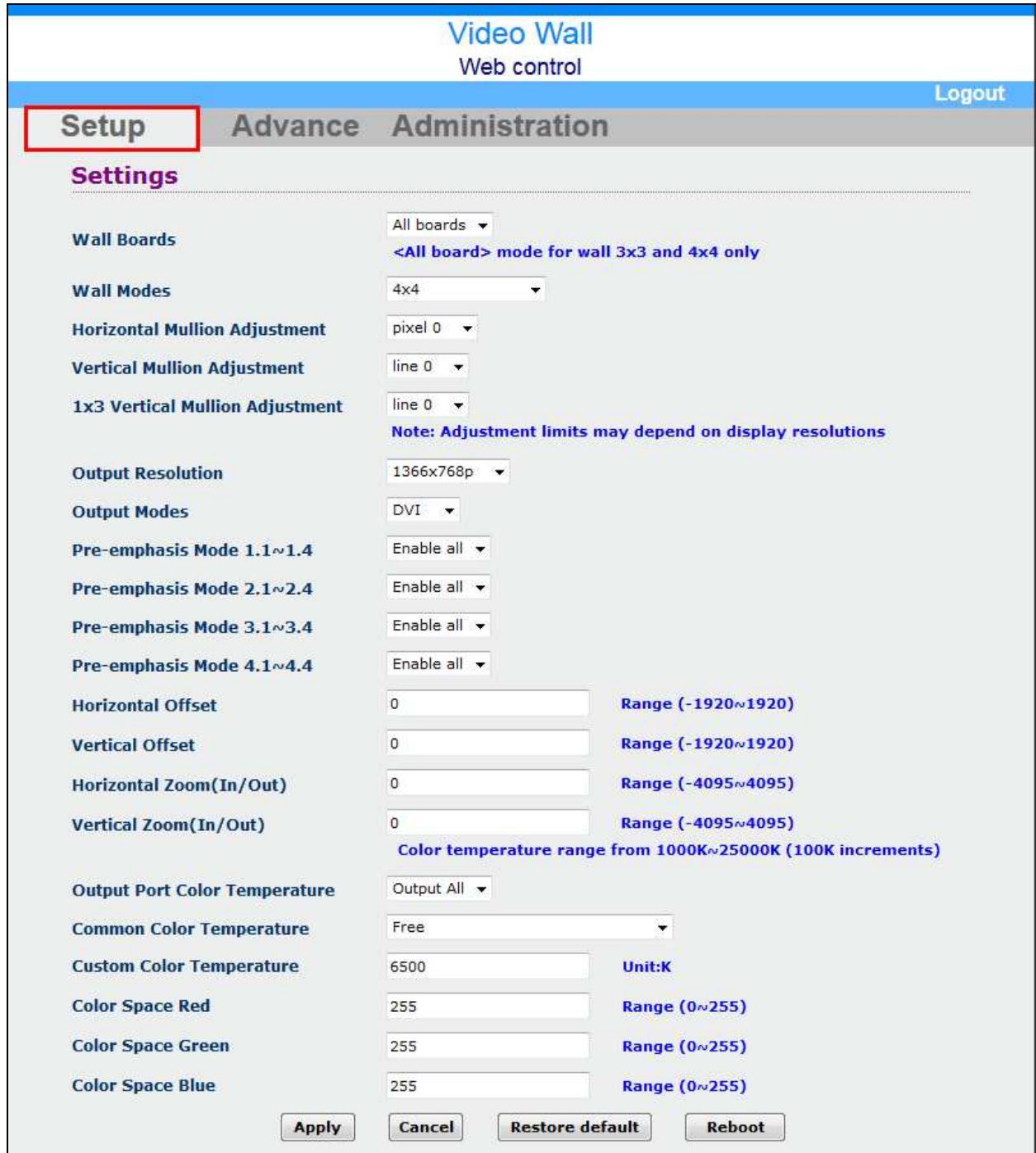

Figure 30: Web Control - Setup

7.1.1 Monitor Arrangements and Settings

■ Wall Boards

Select which video wall module will be affected when the “**Apply**” button is clicked, applying the settings currently shown on the page. For more information, please refer to [Appendix B Video Wall Configuration](#).

☞ All boards mode are applied for wall 3x3 and 4x4 only.

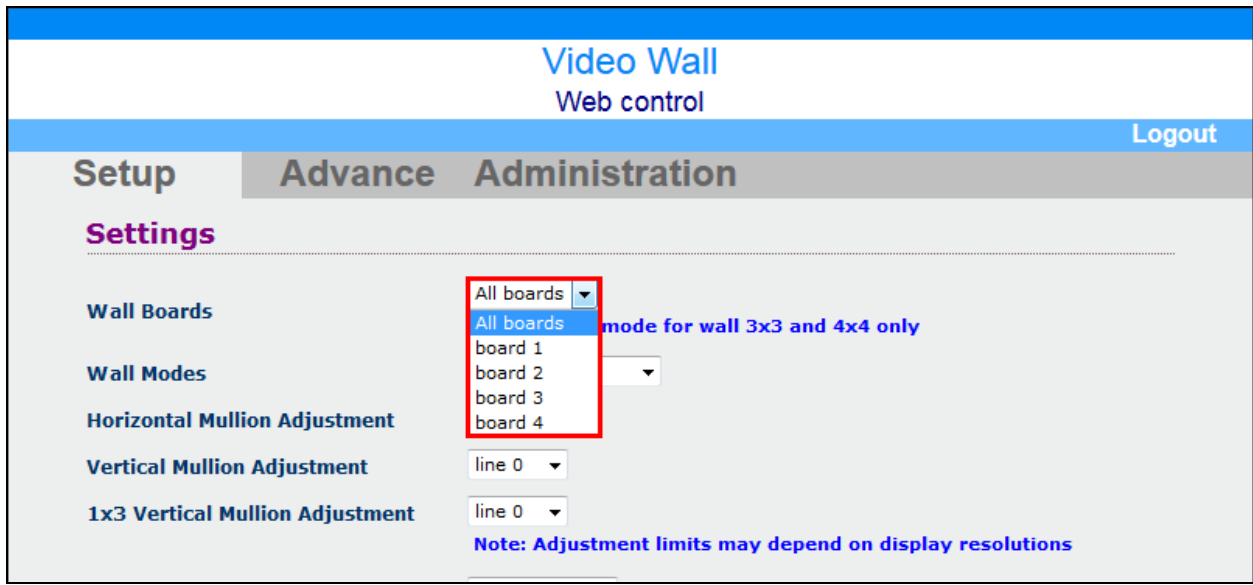

Figure 31: Wall Board

■ **Wall Modes**

Select the video wall monitor arrangement. This determines how the input image is split and which outputs are driven with which piece of the input image.

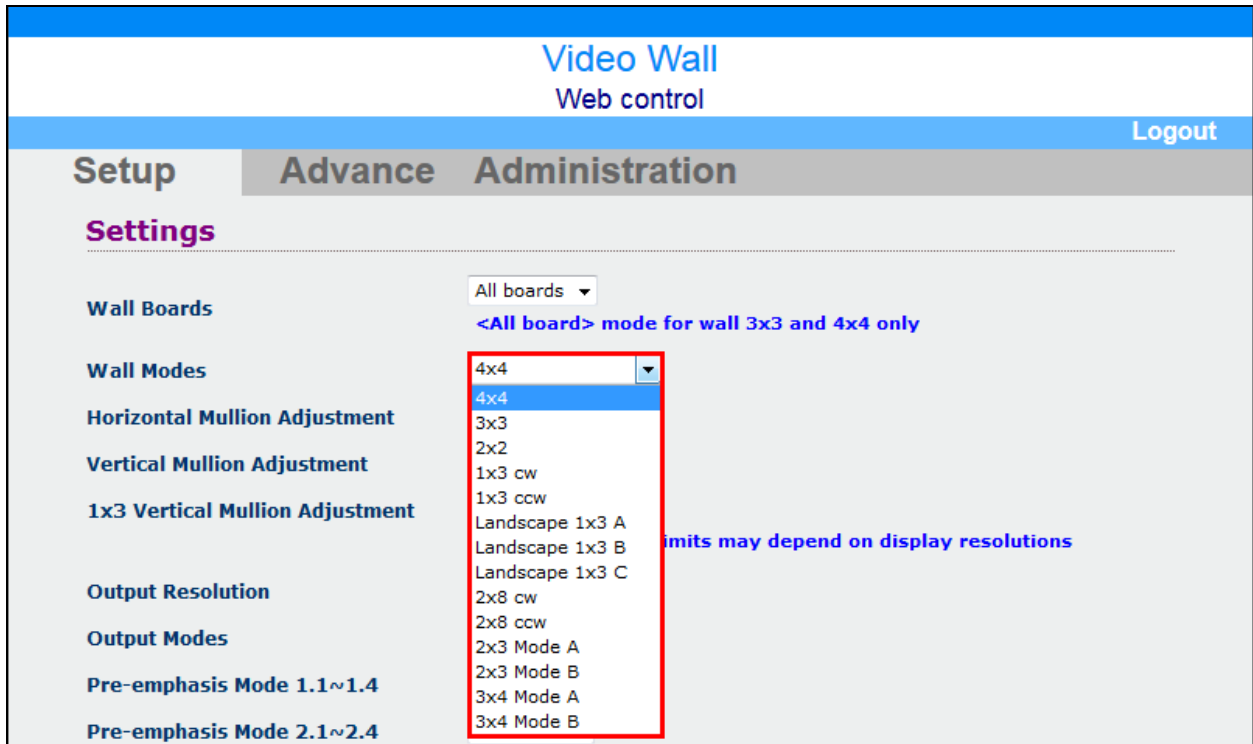

Figure 32: Wall Modes

QW-202S (H) Wall Modes values:

2x2, 1x3 cw, 1x3 ccw, Landscape 1x3 A, Landscape 1x3 B and Landscape 1x3 C.

QW-303S (H) Wall Modes values:

3x3, 2x2, 1x3 cw, 1x3 ccw, Landscape 1x3 A, Landscape 1x3 B, Landscape 1x3 C, 2x3 Mode A, 2x3 Mode B, 3x4 Mode A and 3x4 Mode B.

QW-404S (H) Wall Modes values:

4x4, 3x3, 2x2, 1x3 cw, 1x3 ccw, Landscape 1x3 A, Landscape 1x3 B, Landscape 1x3 C, 2x8 cw, 2x8 ccw, 2x3 Mode A, 2x3 Mode B 3x4 Mode A and 3x4 Mode B. Refer to [Appendix B Video Wall Configuration](#).

■ **Output Resolution**

Set the resolution of the output ports. Adjust this setting to match your video wall monitor's capability. The QW Series support both 1920x1080p and 1366x768p output Resolutions. The default value is **1920x1080p**.

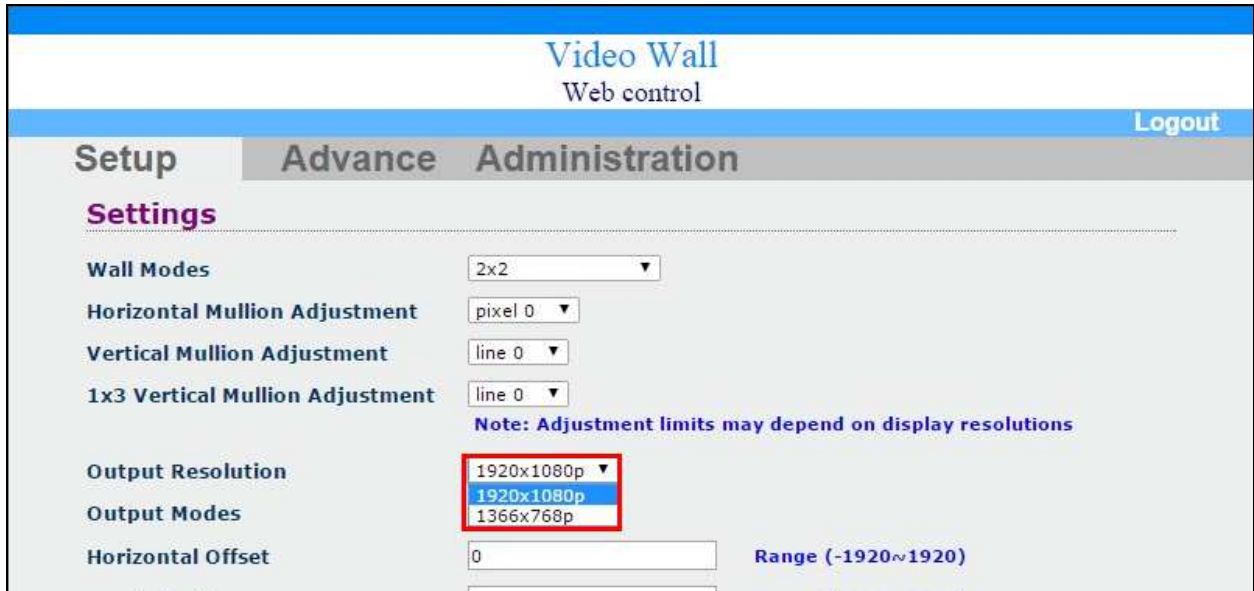

Figure 33: Output Resolution

■ **Output Modes**

Select for either HDMI or DVI type video signal. Adjust this setting to match your video wall monitor's capability. The default value is either **DVI** or **HDMI** based on the connection interface.

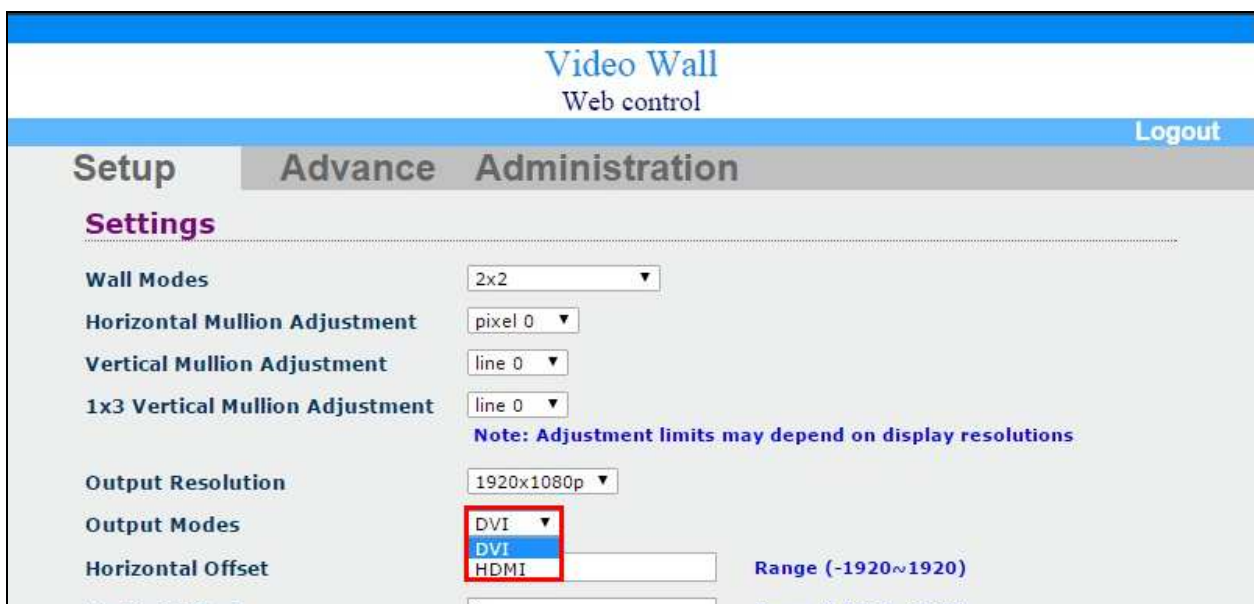

Figure 34: Output Modes

7.1.2 Mullion Adjustments

☞ Adjustment limits may depend on display resolutions.

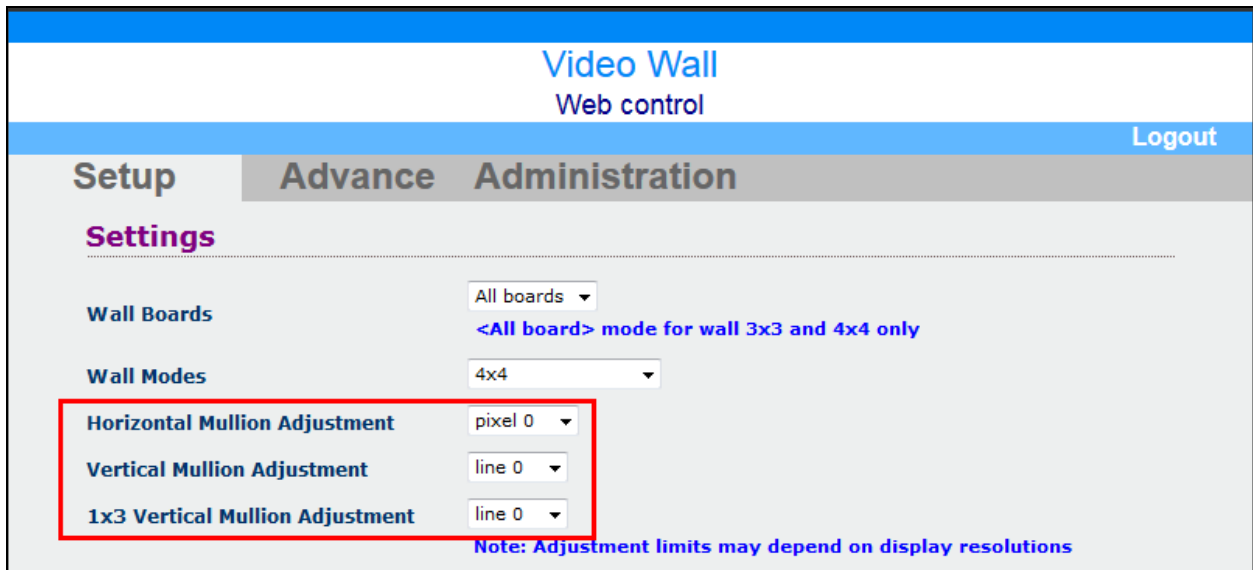

Figure 35: Mullion Adjustment

Mullion adjustments compensate for the width of the monitor's frame.

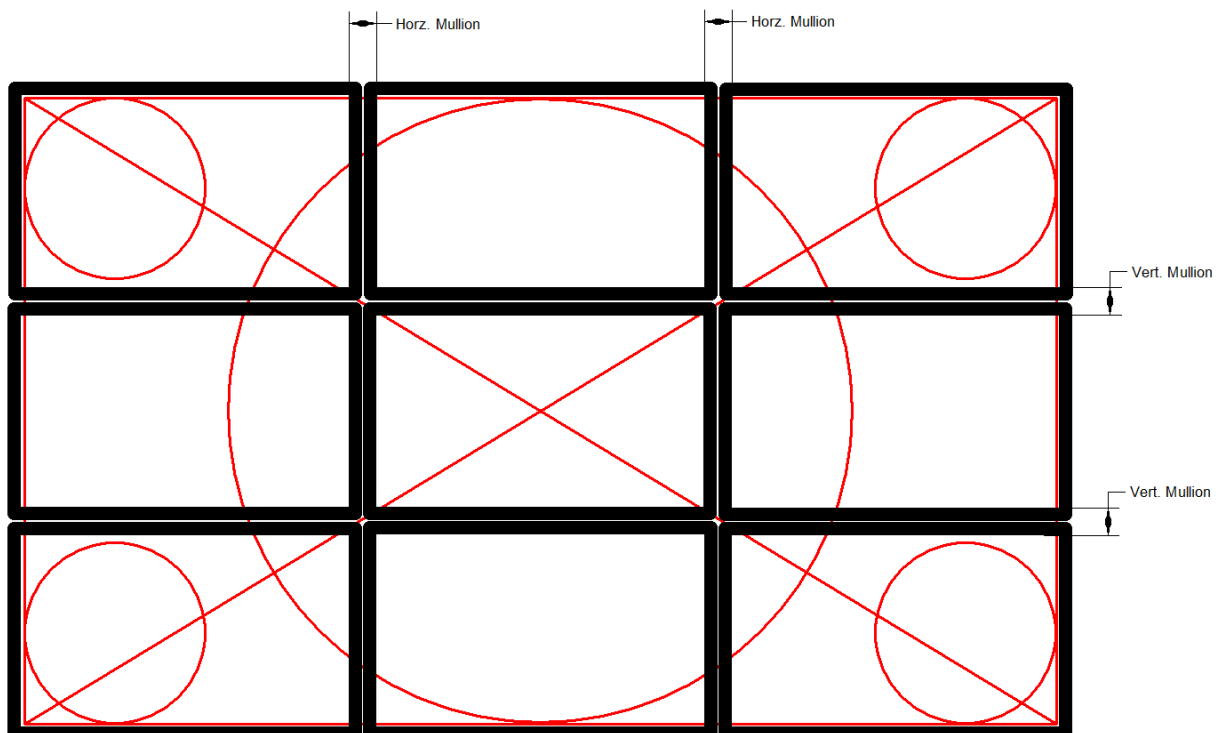

Figure 36: Mullion Adjustment Compensation

- **Horizontal Mullion Adjustment**

Select the width of the portion of image to be removed, in pixels. (The value is from pixel 0 to pixel 36)

- **Vertical Mullion Adjustment**

Select the height of the portion of image to be removed, in video lines. (The value is from line 0 to line 36)

- **1x3 Vertical Mullion Adjustment**

Select the width of the portion of image to be removed, in lines. This setting is also in line since the monitors will be in “**portrait**” mode. (The value is from line 0 to line 36)

7.1.3 Offset and Zoom Settings

These settings effectively crop and position the input image relative to the video wall.

- **Horizontal Offset:** The range is -1920~1920.
- **Vertical Offset:** The range is -1920~1920.
- **Horizontal Zoom (In/Out):** The range is -1920~1920.
- **Vertical Zoom (In/Out):** The range is -1920~1920.

7.1.4 Color Settings

These settings can adjust the output video color, either to all monitors, or to individual monitors to compensate for disparate monitors.

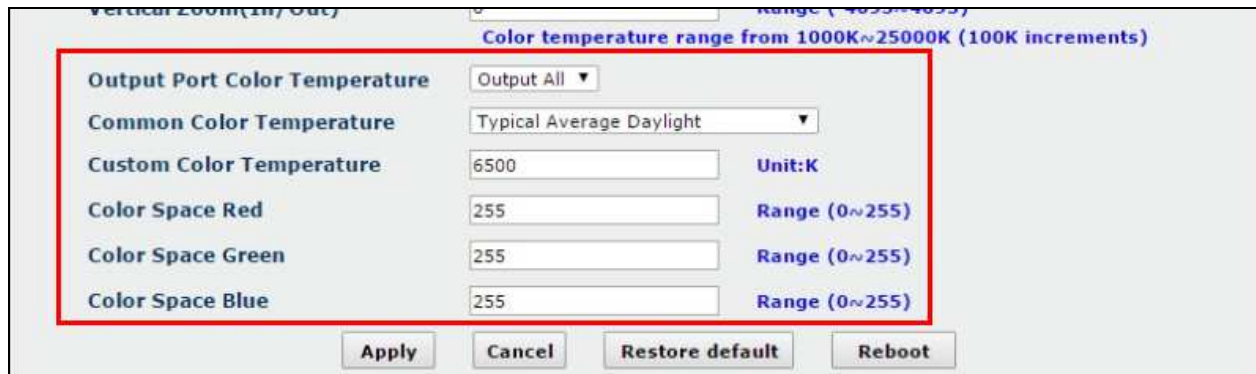

Figure 37: Color Settings

- **Output Port Color Temperature**

Select which output ports are affected by the settings when the “**Apply**” button is clicked. The default value is **Output All**.

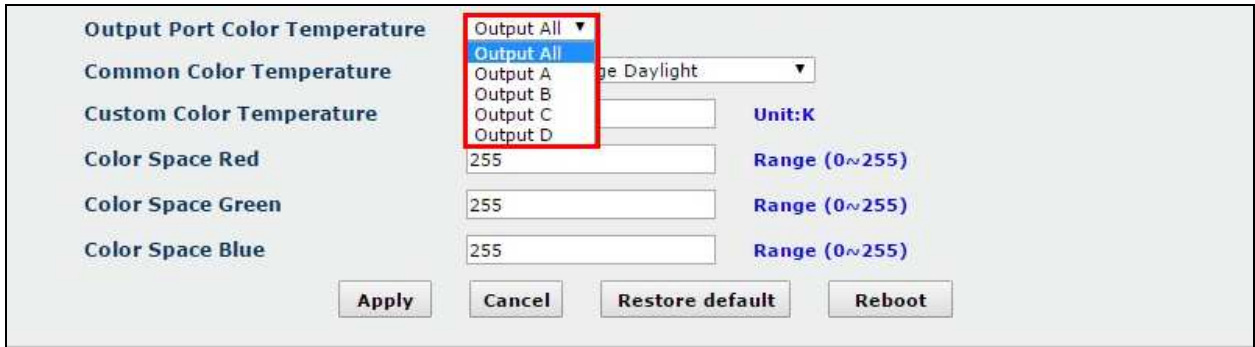

Figure 38: Output Port Color Temperature

■ **Common Color Temperature**

Select from a list of the most common preset color temperature schemes. The default value is **Typical Average Daylight**.



Figure 39: Common Color Temperature

■ **Custom Color Temperature**

User configured custom setting. Color temperature is conventionally expressed in Kelvin, using the symbol K, a unit of measure for temperature based on the Kelvin scale. The higher color temperatures are called cool colors (bluish white), while lower color temperatures are called warm colors (yellowish white through red). The default value is **6500** Kelvin.



Figure 40: Color Temperature Bar

■ **Color Space Red / Green / Blue**

User configured custom setting. A color's RGB value indicates its red, green and blue intensity. Each intensity value is on a scale of 0 to 255. These default values are **255**.

| RGB Value | | | Colour |
|-----------|-------|------|--------|
| Red | Green | Blue | |
| 0 | 0 | 0 | black |
| 255 | 255 | 255 | white |
| 255 | 255 | 0 | yellow |
| 255 | 130 | 255 | Pink |
| 146 | 81 | 0 | brown |
| 157 | 95 | 82 | purple |
| 140 | 0 | 0 | maroon |

These are the 3 colors used to adjust the output image color that you see. For example:



Add Red Color Value



Add Green Color Value



Add Blue Color Value

Figure 41: RGB Adjustment

☞ Click **“Restore Default”** button to restore all the changed values to factory default or click **“Apply”** button to accept the changed values and click **“Reboot”** button to make the changed values take effect properly.

7.2 Advance

For the **Advance** tab including **TFTP Server IP** and **File Name** configurations. The **Advance** Tab does not contain configuration settings, and should only be used by field service personnel.

The screenshot displays the 'Video Wall Web control' interface. At the top, there is a blue header with 'Video Wall' and 'Web control' text, and a 'Logout' link on the right. Below the header is a navigation bar with three tabs: 'Setup', 'Advance' (highlighted with a red box), and 'Administration'. A red warning message is displayed below the tabs: 'Warning! Before you proceed with any changes on this page, please first consult.' The main content area is titled 'Firmware Upgrade Settings' and contains two input fields: 'TFTP Server IP' with the value '192.168.1.10' and 'File Name' with the value 'firmware.bin'. At the bottom of the form are three buttons: 'Apply', 'Cancel', and 'FirmwareUpgrade'.

Figure 42: Web Control - Advance

⚠ Before you proceed with any changes on this page, please consult your agency firstly.

7.3 Administration

The screenshot shows the 'Administration' page of the Video Wall Web Control interface. The page is titled 'Video Wall' and 'Web control'. It features a navigation bar with 'Setup', 'Advance', and 'Administration' tabs, with 'Administration' being the active tab. The page is divided into three sections: 'Username', 'Password', and 'Network'. Each section contains input fields and 'Apply' and 'Cancel' buttons.

| Section | Field Name | Value |
|----------|------------------------|---------------|
| Username | Username | |
| | Buttons | Apply, Cancel |
| Password | Old Password | |
| | New Password | |
| | Confirm Password | |
| Buttons | Apply, Cancel | |
| Network | Static IP Address | 192.168.1.151 |
| | Static Subnet Mask | 255.255.255.0 |
| | Static Default Gateway | 192.168.1.1 |
| | Static DNS Server | 168.95.1.1 |
| Buttons | Apply, Cancel | |

Figure 43: Web Control - Administration

7.3.1 Username

The default username for logging on to these setup webpage is **"admin"**. This can be changed to your preference. Click the corresponding **"Apply"** button after entering your information.

7.3.2 Password

The default password for logging on to these setup webpage is **"admin"**. This can be changed to your preference. Click the corresponding **"Apply"** button after entering your information.

7.3.3 Network

- **Static IP Address**

The IP Address of the device. This should be set to an address on the same subnet as the computer (or network) it will be controlled from.

- **Static Subnet Mask**

Default subnet masks depend on the class of your network.

| Network class | Network IP addresses | Subnet Mask |
|---------------|----------------------|---------------|
| Class A | 10.xxx.xxx.xxx | 255.255.0.0 |
| Class B | 172.xxx.xxx.xxx | 255.255.240.0 |
| Class C | 192.168.xxx.xxx | 255.255.255.0 |

- **Static Default Gateway**

Set as applicable for your network. Contact your I.T. department.

- **Static DNS Server**

Set as applicable for your network. Contact your I.T. department.

CHAPTER 8 TROUBLESHOOTING

1. What to do if LED is fail in display?

Answer: Check the connection of power cord is not loosening and the power cord is in a good status having no any damage. Check the power source is normally.

2. What to do if you sense the power leakage during plugging or unplugging of the input/output ports?

Answer: It could be that the equipment power is not properly grounded. You must properly ground your equipment; otherwise product life can easily be shortened.

3. What to do if operation and function failure occurred?

Answer: Check if the equipment and the splitter or D.A system are in proper connection. If the problem persists, send the product to the maintenance center for repair.

4. How to avoid the equipment failure due to the high temperature?

Answer: Place the equipment in a ventilate location. If it is still not to be improved, please check with the build-in fan whether is damaged. Or contact your agency for helping.

5. What to do if IR function failure occurred?

Answer: Check the battery of remote controller is NOT running low and the IR connector is not loosening. Check whether the remote controller is aiming at the IR receiver accurately.

APPENDIX A EXTENDER (OPTIONAL)

The extension of HDMI video signal device supports up to 70 meter away by using an Extender and Cat.5e cable. For more information, please contact your agency.



Figure 44: Extender

Extender Connection

1. Turn off the HDTV.
2. Connect the HDMI cable between the HDTV and the “**HDMI OUT**” port of Extender.
3. Connect the Cat.5e cables between QW Series Output port and the “**LINK**” port of Extender.
4. Connect the power cord and turn on the Extender.
5. Turn on the HDTV.

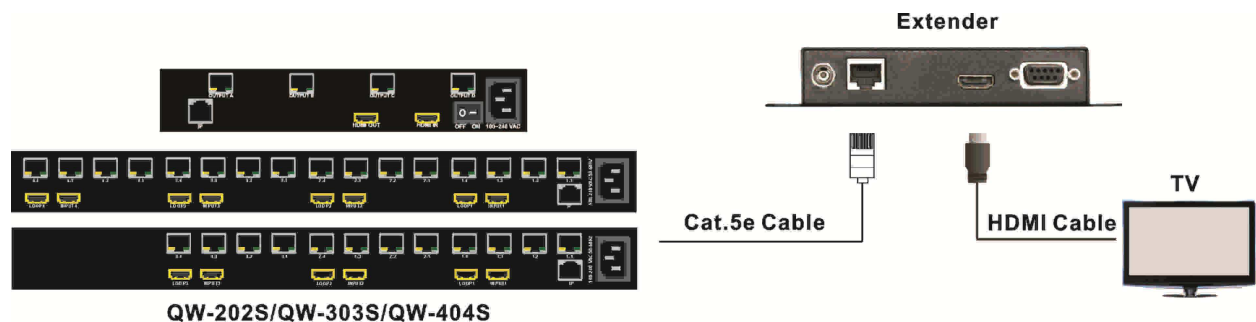

Figure 45: Extender Connection

APPENDIX B VIDEO WALL CONFIGURATION

Both QW-303S (H) and QW-404S (H) are support the **Wall Boards** configurations. The configurations for QW-303S (H) are almost the same as QW-404S (H). This section will introduce you some of the normal video wall connections and signals transmission for QW-404S (H). The pictures as below are the combined reference for **All boards** and each wall mode.

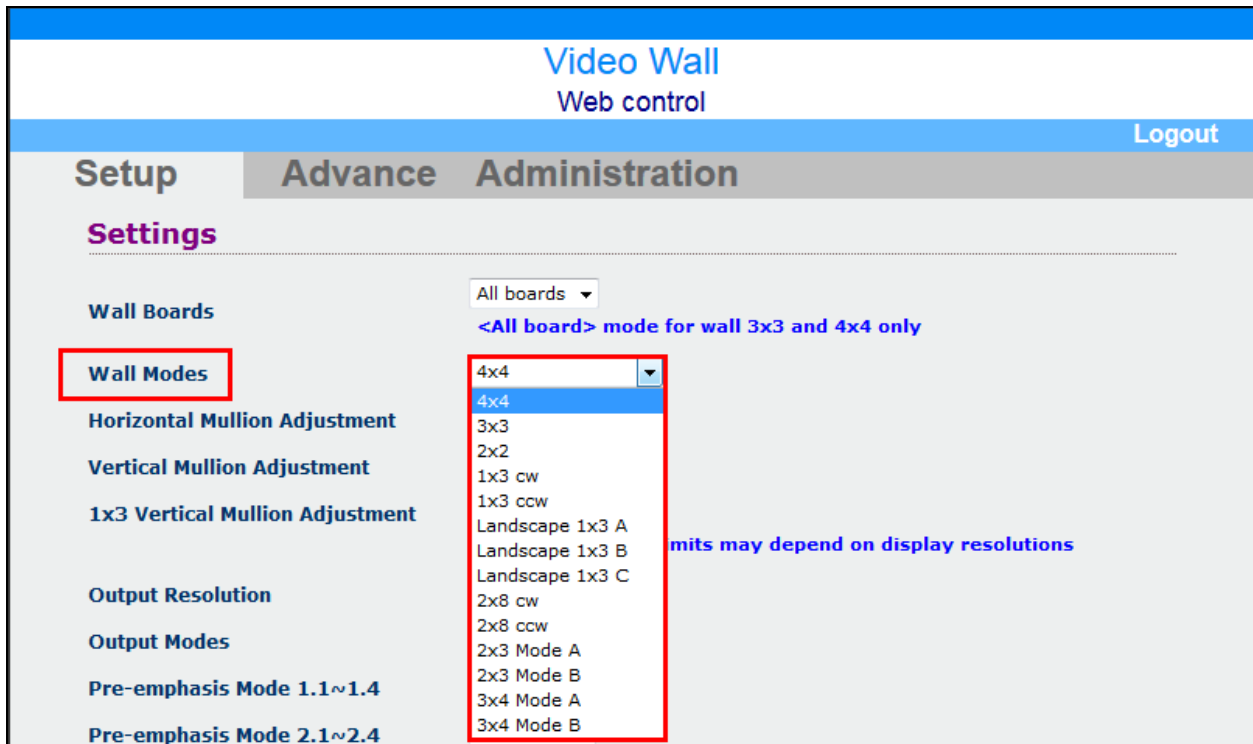

Figure 46: Wall Modes List for QW-404x

Wall Modes values:

4x4, 3x3, 2x2, 1x3 cw, 1x3 ccw, Landscape 1x3 A, Landscape 1x3 B, Landscape 1x3 C, 2x8 cw, 2x8 ccw, 2x3 Mode A, 2x3 Mode B 3x4 Mode A and 3x4 Mode B.

The following sections describe the configuration of the output ports and the combination of output images.

2x2 Mode

Connection 1:

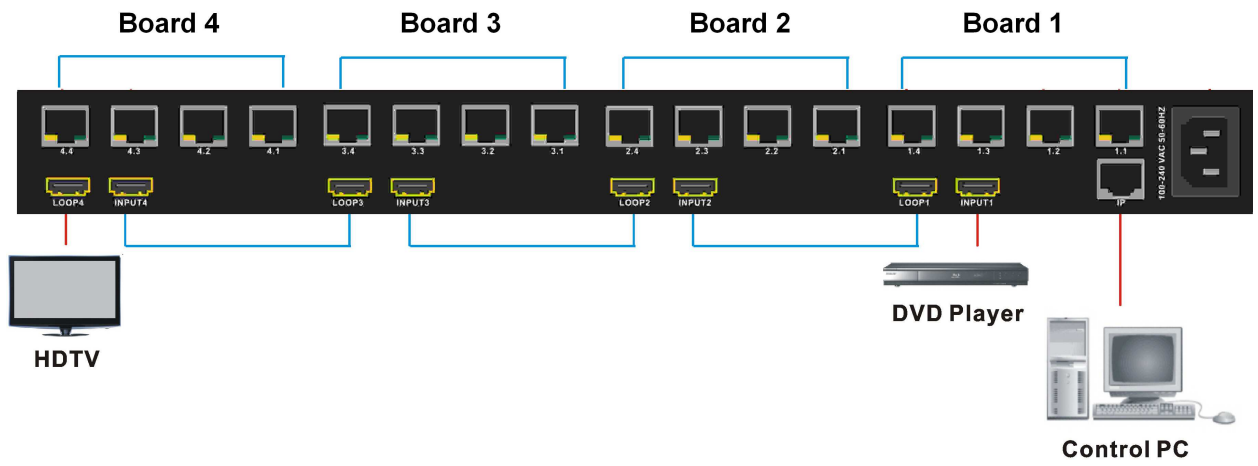

Original Import Image

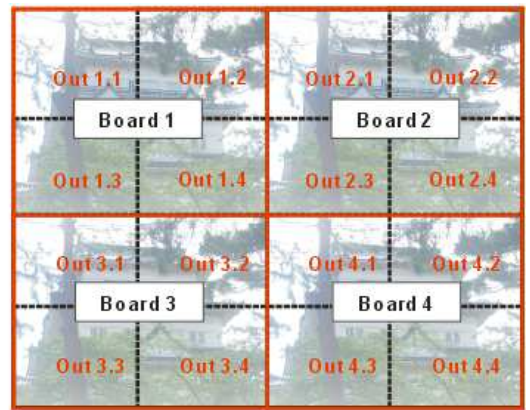
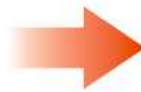

Output Image through the output ports

Figure 47: 2x2 Mode Status 1

Connection 2:

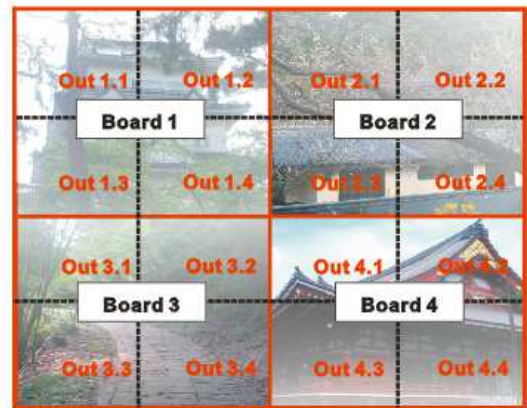
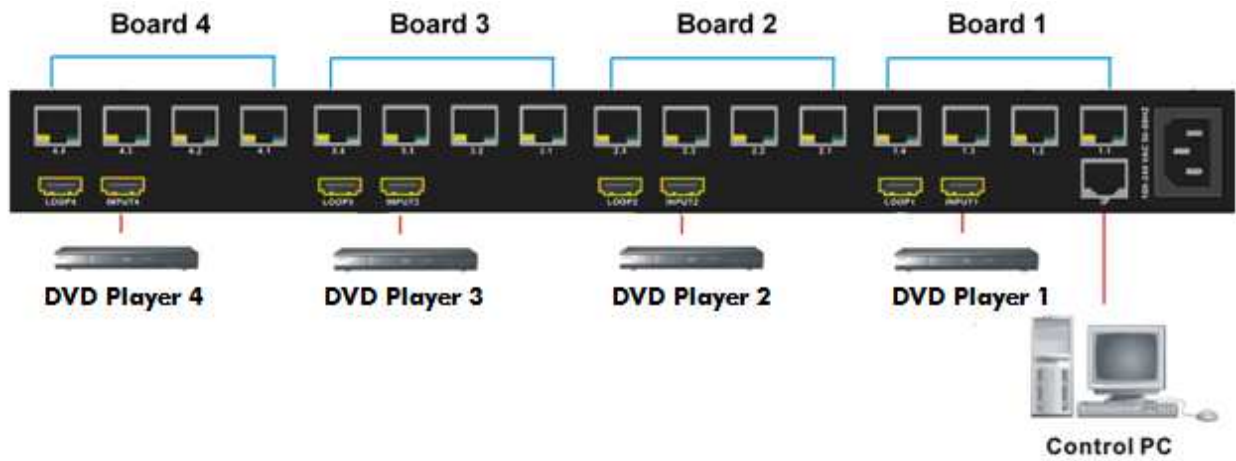

Original Import Image

Output Image through the output ports

Figure 48: 2x2 Mode Status 2

Connection 3:

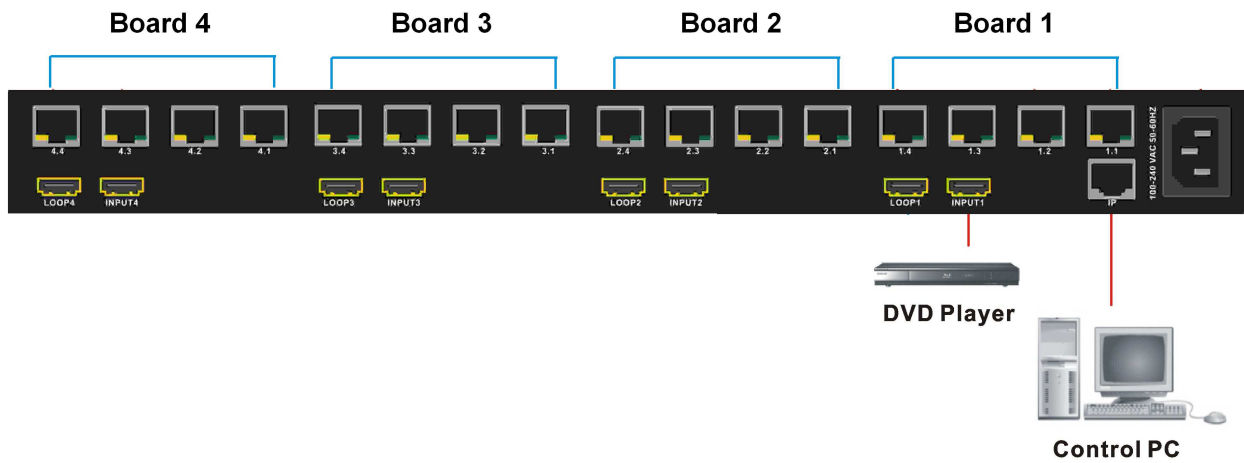

Original Import Image

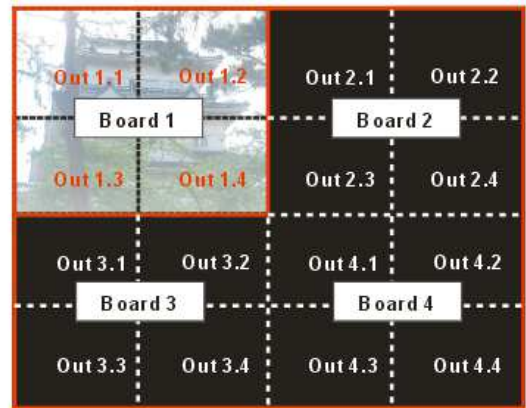
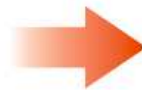

Output Image through the output ports

Figure 49: 2x2 Mode Status 3

3x3 Mode



Original Import Image

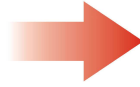

Output Image through the output ports

Figure 50: 3x3 Mode

☞ Output ports: Out 4.1~Out 4.4, Out 1.4, Out 2.4, Out 3.4 and Out 4.4 are not used.

4x4 Mode



Original Import Image

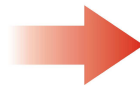

Output Image through the output ports

Figure 51: 4x4 Mode

1x3 CW Mode



Original Import Image

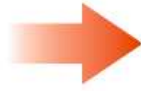

| | | | |
|---------|---------|---------|---------|
| Out 1.1 | Out 2.1 | Out 3.1 | Out 4.1 |
| Out 1.2 | Out 2.2 | Out 3.2 | Out 4.2 |
| Out 1.3 | Out 2.3 | Out 3.3 | Out 4.3 |
| Out 1.4 | Out 2.4 | Out 3.4 | Out 4.4 |

Output Image through the output ports

Figure 52: 1x3 CW Mode

☞ Output ports: Out 1.4, Out 2.4, Out 3.4 and Out 4.4 are not used.

1x3 CCW Mode



Original Import Image

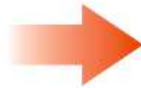

| | | | |
|---------|---------|---------|---------|
| Out 1.1 | Out 2.1 | Out 3.1 | Out 4.1 |
| Out 1.2 | Out 2.2 | Out 3.2 | Out 4.2 |
| Out 1.3 | Out 2.3 | Out 3.3 | Out 4.3 |
| Out 1.4 | Out 2.4 | Out 3.4 | Out 4.4 |

Output Image through the output ports

Figure 53: 1x3 CCW Mode

☞ Output ports: Out 1.4, Out 2.4, Out 3.4 and Out 4.4 are not used.

Landscape 1x3 A/B/C Mode

Landscape 1x3 A



Original Import Image



| | | | |
|---------|---------|---------|---------|
| Out 1.1 | Out 2.1 | Out 3.1 | Out 4.1 |
| Out 1.2 | Out 2.2 | Out 3.2 | Out 4.2 |
| Out 1.3 | Out 2.3 | Out 3.3 | Out 4.3 |
| Out 1.4 | Out 2.4 | Out 3.4 | Out 4.4 |

Output Image through the output ports

Figure 54: Landscape 1x3 A Mode

Landscape 1x3 B



Original Import Image

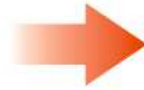

| | | | |
|---------|---------|---------|---------|
| Out 1.1 | Out 2.1 | Out 3.1 | Out 4.1 |
| Out 1.2 | Out 2.2 | Out 3.2 | Out 4.2 |
| Out 1.3 | Out 2.3 | Out 3.3 | Out 4.3 |
| Out 1.4 | Out 2.4 | Out 3.4 | Out 4.4 |

Output Image through the output ports

Figure 55: Landscape 1x3 B Mode

Landscape 1x3 C



Original Import Image



| | | | |
|---------|---------|---------|---------|
| Out 1.1 | Out 2.1 | Out 3.1 | Out 4.1 |
| Out 1.2 | Out 2.2 | Out 3.2 | Out 4.2 |
| Out 1.3 | Out 2.3 | Out 3.3 | Out 4.3 |
| Out 1.4 | Out 2.4 | Out 3.4 | Out 4.4 |

Output Image through the output ports

Figure 56: Landscape 1x3 C Mode

☞ Output ports: Out 1.4, Out 2.4, Out 3.4 and Out 4.4 are not used. Partition 1 to 4 output ports will transmit the signals independently.

3x4 Mode A / 3x4 Mode B

3x4 Mode A



Original Import Image

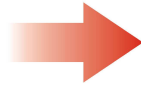

Output Image through the output ports

Figure 57: 3x4 Mode A

3x4 Mode B



Original Import Image

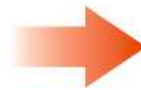

Output Image through the output ports

Figure 58: 3x4 Mode B

2x3 Mode A / 2x3 Mode B

2x3 Mode A



Original Import Image

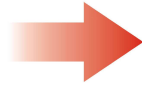

| | | | |
|---------|---------|---------|---------|
| Out 1.1 | Out 1.2 | Out 1.3 | Out 1.4 |
| Out 2.1 | Out 2.2 | Out 2.3 | Out 2.4 |
| Out 3.1 | Out 3.2 | Out 3.3 | Out 3.4 |
| Out 4.1 | Out 4.2 | Out 4.3 | Out 4.4 |

Output Image through the output ports

Figure 59: 2x3 Mode A

2x3 Mode B



Original Import Image



| | | | |
|---------|---------|---------|---------|
| Out 1.1 | Out 1.2 | Out 1.3 | Out 1.4 |
| Out 2.1 | Out 2.2 | Out 2.3 | Out 2.4 |
| Out 3.1 | Out 3.2 | Out 3.3 | Out 3.4 |
| Out 4.1 | Out 4.2 | Out 4.3 | Out 4.4 |

Output Image through the output ports

Figure 60: 2x3 Mode B

2x8 CW / 2x8 CCW

2x8 CW



Original Import Image

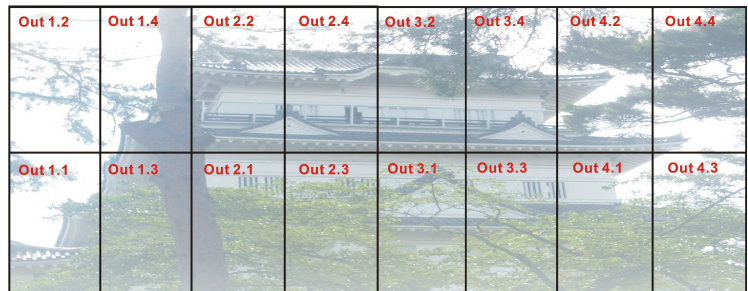

Output Image through the output ports

Figure 61: 2X8 CW Mode

2x8 CCW



Original Import Image

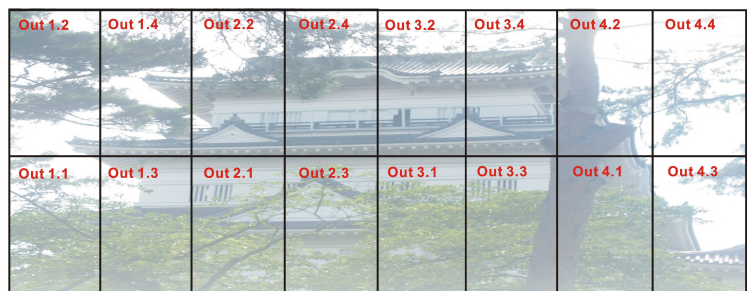

Output Image through the output ports

Figure 62: 2X8 CCW Mode