

Gehäuse kann um 90°
versetzt montiert werden

4pol / 5pol

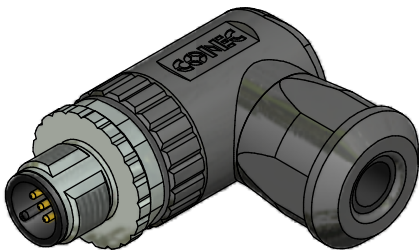
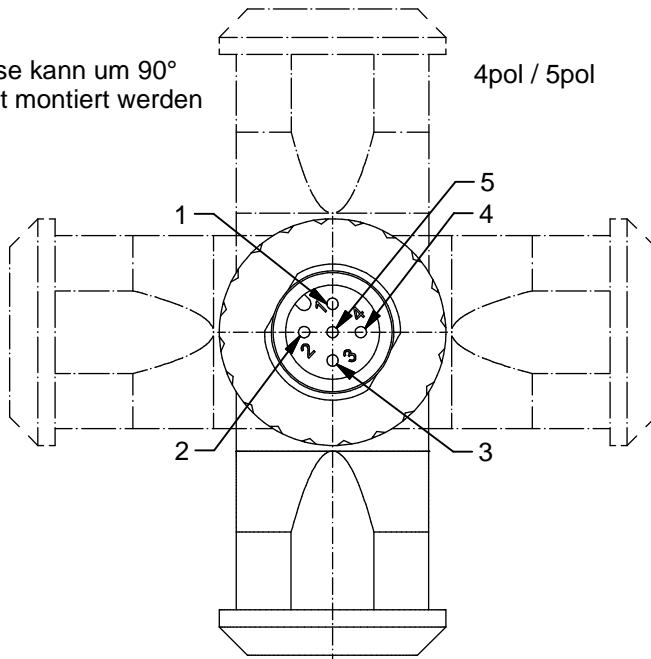

Technische Daten:

Bemessungsspannung: IEC 61076-2-101	4pol 5pol 250 V 60 V
Strombelastbarkeit: IEC 61076-2-101	4 A bei 40°C
Isolationswiderstand: IEC 60512	>=100 MΩ
Verschmutzungsgrad: IEC 60664-1	3/2
Schutzart: IEC 60529	IP 67, im verschraubten Zustand
Umgebungstemperatur: IEC 60664-1	-30°C ... +85°C
Steckzyklen: IEC 60512-9a	>=100
Anschlussquerschnitt:	max. 0,75 mm ²

Werkstoffe:

Kontakt:	CuZn
Kontaktoberfläche:	Ni, Au gal.
Kontaktträger:	PA6, UL 94
Schraubanschluss:	CuZn / Ni, Sn gal.
Kabdichtung:	Elastomere
O-Ring:	FKM / NBR
Überwurfschraube:	GD-Zn, Ni
Gehäuse:	PA6 GF, UL 94

Montage:

empfohlenes Drehmoment:	0,6 Nm
Conec Montagewerkzeug:	Drehmomentschlüssel: 36-000200 Steckeinsatz SW18: 36-000240

Art.-Nr.:	Bezeichnung:	Pol:	Kabel-Ø:
43-00104	SAL - 12 - RSWC4 - S / 075	4	4 - 8 mm
43-00106	SAL - 12 - RSWC5 - S / 075	5	4 - 8 mm

Benennung: Stecker M12x1, konfektionierbar, gewinkelt, Schraubanschluss	
Zeichnungsnr.:	
43K1A837	
Artikelnr.:	siehe Tabelle

CAD-Unterlage nicht manuell ändern
Directive 2002/95/EC RoHS compliant

Index: c 01.02.11 dbu Ä3769
Überwurfschraube geändert,
Schlüsselfläche hinzu, Datenblatt
angepasst

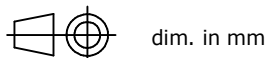

	Datum	Name
gez.	19.01.09	Burschik
gepr.	19.01.09	Schmidt

Diese Zeichnung darf ohne unsere
ausdrückliche, schriftliche Genehmigung
weder vervielfältigt noch dritten Personen
ausgehändigt werden.
Eigentums- und Urheberrecht vorbehalten



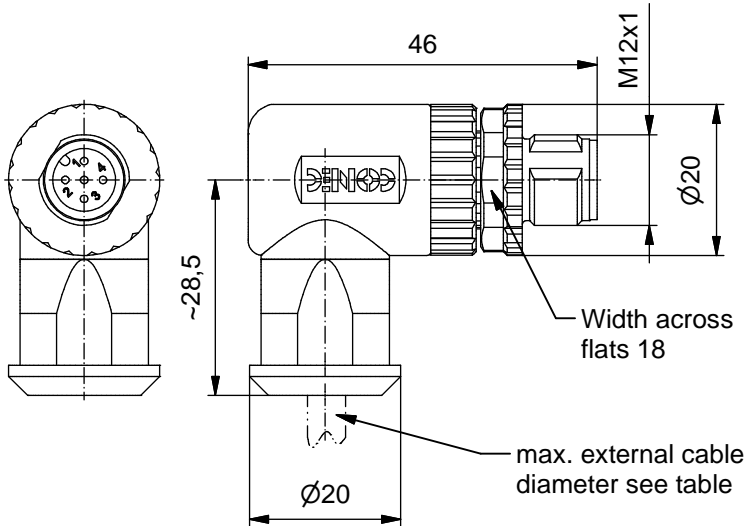

Housing in angled version is mountable in 90° angular degree positions

4pos / 5pos

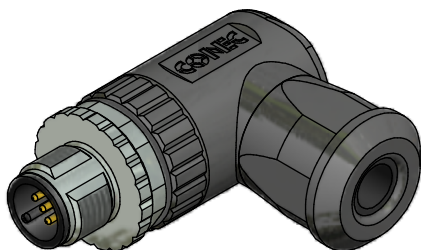
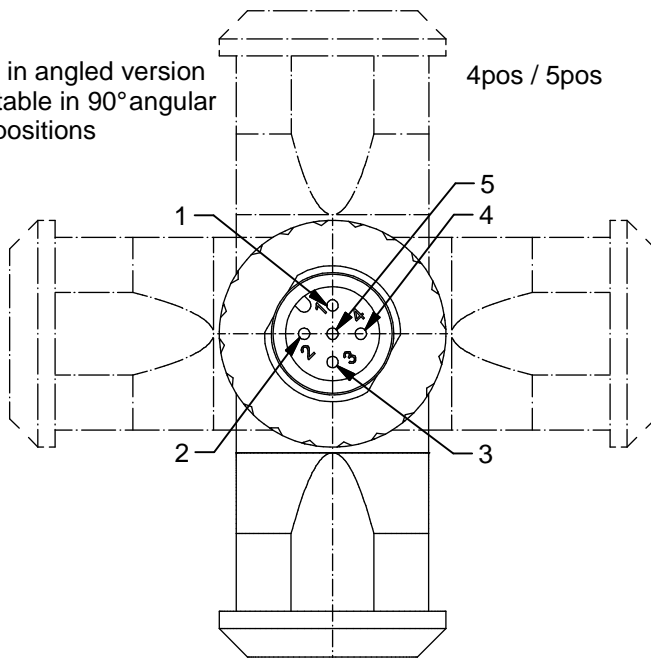

Technical specification:

Rated voltage: IEC 61076-2-101	4pos 5pos 250 V 60 V
Current rating: IEC 61076-2-101	4 A at 40°C
Insulation resistance: IEC 60512	>=100 MΩ
Pollution degree: IEC 60664-1	3/2
Degree of protection: IEC 60529	IP 67, in mated condition
Temperature range: IEC 60664-1	-30°C ... +85°C
Mating cycles: IEC 60512-9a	>=100
Wire cross section:	AWG18 / max. 0,75 mm ²

Materials:

Contact:	CuZn
Contact plating:	Nickel, gold plated
Contact carrier:	PA6, UL 94
Screw connection	CuZn / nickel, tin plated
Cable seal:	Elastomere
O-Ring:	FKM / NBR
Coupling screw:	GD-Zn, nickel plated
Housing:	PA6 GF, UL 94

Installation specification:

Recommended torque:	0,6 Nm
Conec installation tooling:	Torque wrench: 36-000200 Insert across flats 18: 36-000240

Part no:	Description:	Pos:	Cable-Ø:
43-00104	SAL - 12 - RSWC4 - S / 075	4	4 - 8 mm
43-00106	SAL - 12 - RSWC5 - S / 075	5	4 - 8 mm

DO NOT ALTER CAD DRAWING BY HAND
Directive 2002/95/EC RoHS compliant

Index: c 01.02.11 dbu Ä3769
Coupling screw modified, spanner flats added, data sheet modified

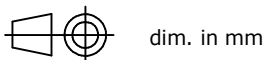

	date	name
drawn	19.01.09	Burschik
appd.	19.01.09	Schmidt

THIS DRAWING MAY NOT BE COPIED OR REPRODUCED IN ANY WAY, AND MAY NOT BE PASSED ON TO A THIRD PARTY WITHOUT WRITTEN PERMISSION.
OWNERSHIP AND COPYRIGHT OF CONEC GmbH



title:	Male connector M12x1, field attachable, angled, screw connection
dwg no:	43K1A837
part no:	see table