



Introduction

Welcome	2
Gigabit connections	2
Features	2
Technical Specifications	3
ALIF3000 unit features.....	4
Supplied items	5
Optional extras.....	6

Installation

Connections	7
Mounting	7
Video displays.....	8
Audio.....	8
USB devices	9
Power in	10
KVM & VM network links	11
VM-only network link.....	12

Configuration

ALIF3000 configuration	13
The recessed power button	13
Performing a manual factory reset.....	13
Creating an RDP session	14

Operation

OLED screen.....	16
Front panel indications.....	17

Further information

Getting assistance	18
Appendix A - Configuration page.....	19
Appendix B - Tips for success when networking ALIF units	20
Appendix C - Troubleshooting	22
Appendix D - Glossary	24
Appendix E - Fiber/copper modules and cables.....	27
Appendix F - Using the optional ALIF3000 rack shelf	28
Appendix G - Open source licenses.....	29

Index

Introduction

WELCOME

Thank you for choosing the ADDERLink™ INFINITY 3000 (aka ALIF3000), a member of the wide ranging ADDERLink INFINITY family of advanced extenders. The ALIF3000 receiver has been created to address the growing requirement to connect users to both physical and virtual machines. Using standard VDI (Virtual Desktop Infrastructure) protocols - which are built-in; the ALIF3000 delivers seamless access to legacy KVM systems as well as Virtual Machine (VM) sources, from the same common console.

Like all products within the ADDERLink INFINITY family, ALIF3000 is fully administered by the AIM application to allow centralized, secure management of all aspects. Note, it is not possible to use ALIF3000 outside of control by AIM.

Dual DisplayPort® video outlets provide support for a single 2560x1600 display or two at a maximum 1920x1200 resolution (60Hz refresh).

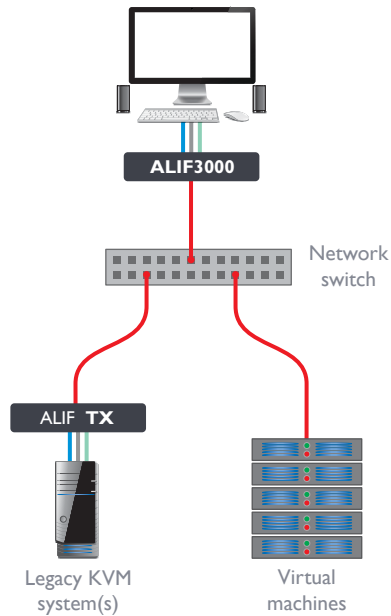

Gigabit connections

The ALIF3000 receiver has two SFP ports located on its rear panel, which can accommodate a range of fiber or copper networking modules, as suits your installation. Each port can be connected to a separate gigabit fiber (or copper) network to permit access to a wider range of systems. A third network port (RJ45) is also provided to allow separate access, where necessary, to a corporate network to gain the VM hosting configuration data. All three connections are securely isolated within the ALIF3000 to prevent any cross contamination between networks.

Features

- Full management via ADDERLink INFINITY Manager (AIM),
- Pixel-perfect picture quality,
- Multiple 1Gb Ethernet links,
- Adder's USB True Emulation for fast USB 2.0 switching,
- Bi-directional analog audio,
- Backwards compatibility with existing ADDERLink INFINITY range.

Safety

Please refer to the safety booklet provided in the box before use of this product.

Technical Specifications

Operating/storage conditions

Operating temperature:	0 to 40°C / 32 to 104°F
Storage temperature:	0 to 40°C / 32 to 104°F
Storage and operating relative humidity:	10 to 90% non-condensing
Altitude:	< 2000m

Power

External power:	12VDC, 5A
Typical power consumption:	20W
BTU:	68.24BTU/hr

Physical

Dimensions	(L)210mm /8.3" x (W)215mm/8.5" x (D)40mm/1.6"
Weight:	1.8kg / 4 lbs

Materials

Aluminium and steel construction

Connectors

Desk:	2x DisplayPort, 6x USB type A, 3x 3.5mm audio jack sockets.
Ethernet:	1x 8p8c (RJ45), 2x SFP+ cages.
Power:	3-pin Kycon socket.

USB

6 ports of USB2.0 with USB True Emulation to support keyboard, mouse and touch.

Max video resolution

Supports 1x 2560x1600 up to maximum refresh rates of 60Hz or 2x 1920x1200

Audio

Analog Line in/out 2 channel 16bit 48KHz 1V RMS in / 1V RMS out

Ethernet

1GbE (10/100/1000 support)

Packing Box

Dimensions:	(L) 285mm /11.2" x (W) 245mm/9.6" x (D)145mm/5.7"
Weight:	2.5kg / 5.5lb

Approvals / Compliance

CE and FCC: See the compliance web page for the full list

Product information labels

The product information labels are located on the base of each unit.

ALIF3000 UNIT FEATURES

The ALIF3000 units are housed within durable, vented enclosures with connectors situated on the front and rear panels. The smart front faces also feature an OLED information screen with control button (to scroll through the various informational pages) and also a status indicator.

Front

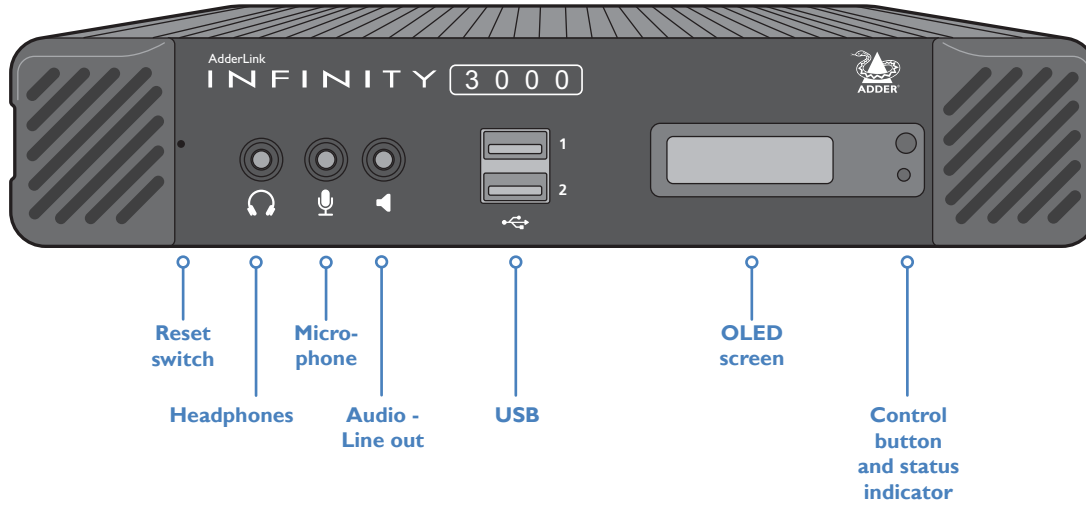

Rear

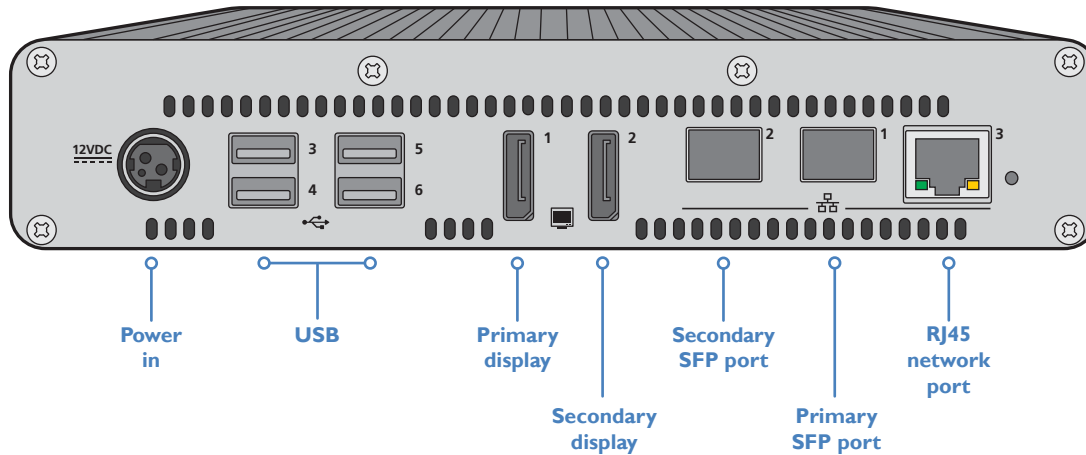

Note: Units shipped before July 1st 2020, will have their network link ports incorrectly labeled in the order (L to R): 1,2, 3.

SUPPLIED ITEMS

ALIF3000 package

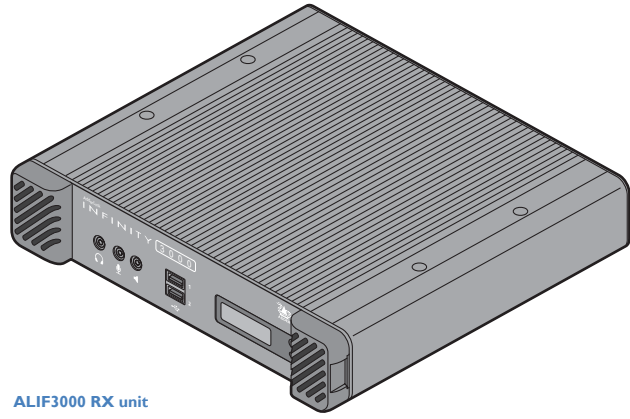

ALIF3000 RX unit

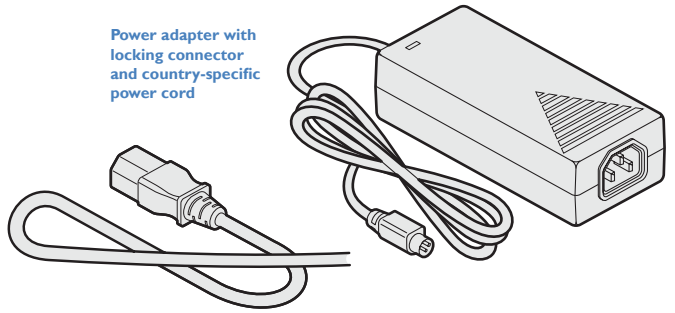

Power adapter with locking connector and country-specific power cord

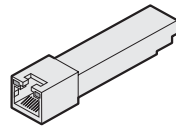

1GbE copper SFP module

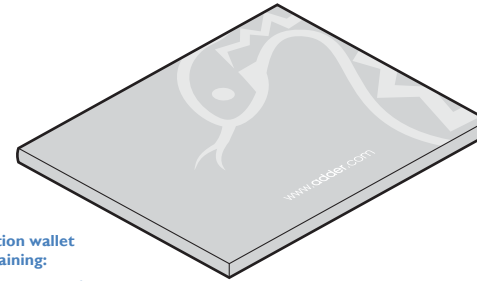

Information wallet containing:

- Four self-adhesive rubber feet
- Quick start guide
- Safety document

OPTIONAL EXTRAS

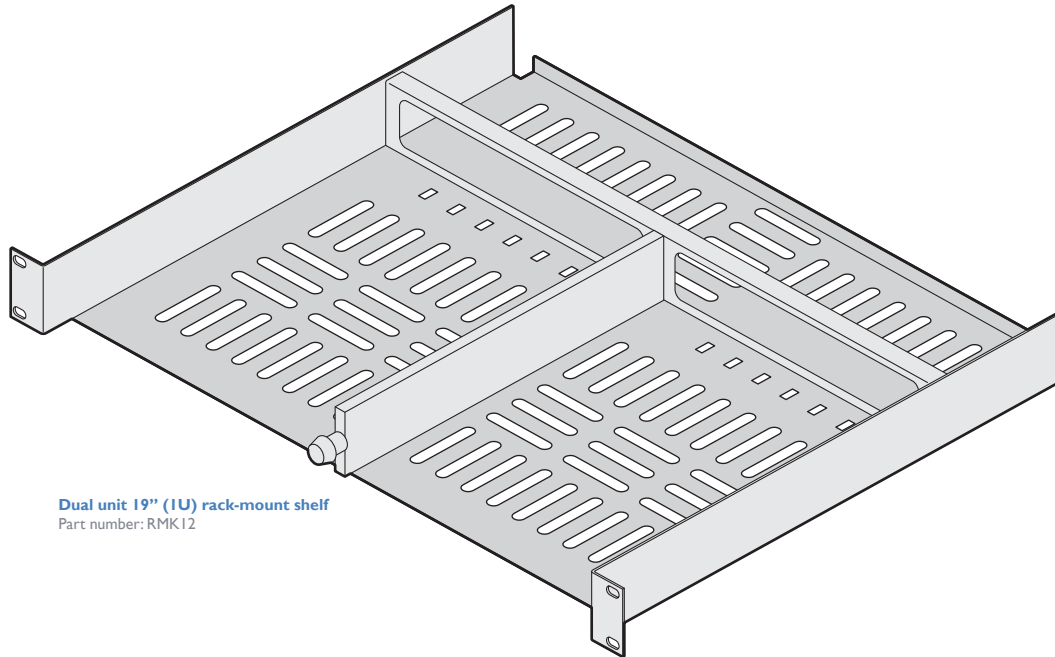

Dual unit 19" (1U) rack-mount shelf
Part number: RMK12

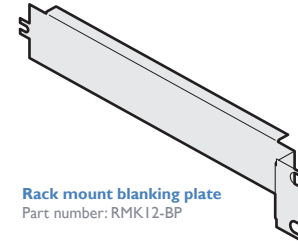

Rack mount blanking plate
Part number: RMK12-BP

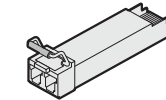

1GbE single mode fiber SFP module
Part number: SFP-SM-LC

Please refer to the table in [Appendix F](#) for information about fiber modules and cables.

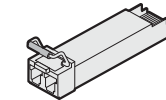

1GbE multi mode fiber SFP module
Part number: SFP-MM-LC

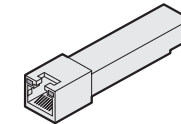

1GbE copper SFP module
Part number: SFP-CATX-RJ45

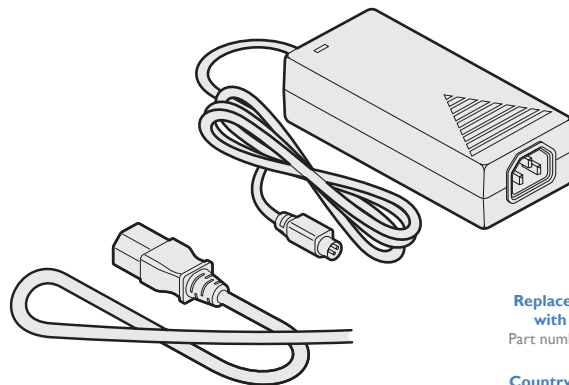

Replacement power adapter with locking connector
Part number: PSU-IEC-12VDC-5A

- Country-specific power cords**
- CAB-IEC-AUS (Australia)
 - CAB-IEC-EURO (Central Europe)
 - CAB-IEC-UK (United Kingdom)
 - CAB-IEC-USA (United States)
 - CAB-IEC-JP (Japan)
 - CAB-IEC-CN (China)

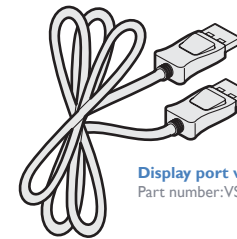

Display port video cable 2m
Part number: VSCD10A

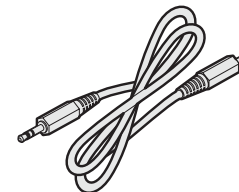

Audio cable 2m (3.5mm stereo jacks)
Part number: VSC22

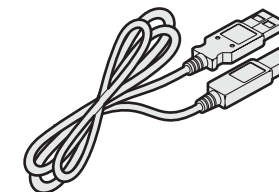

USB cable 2m (type A to B)
Part number: VSC24

CONNECTIONS

Installation involves linking the ALIF3000 unit to networks and your peripherals (collectively known as the *Console*):

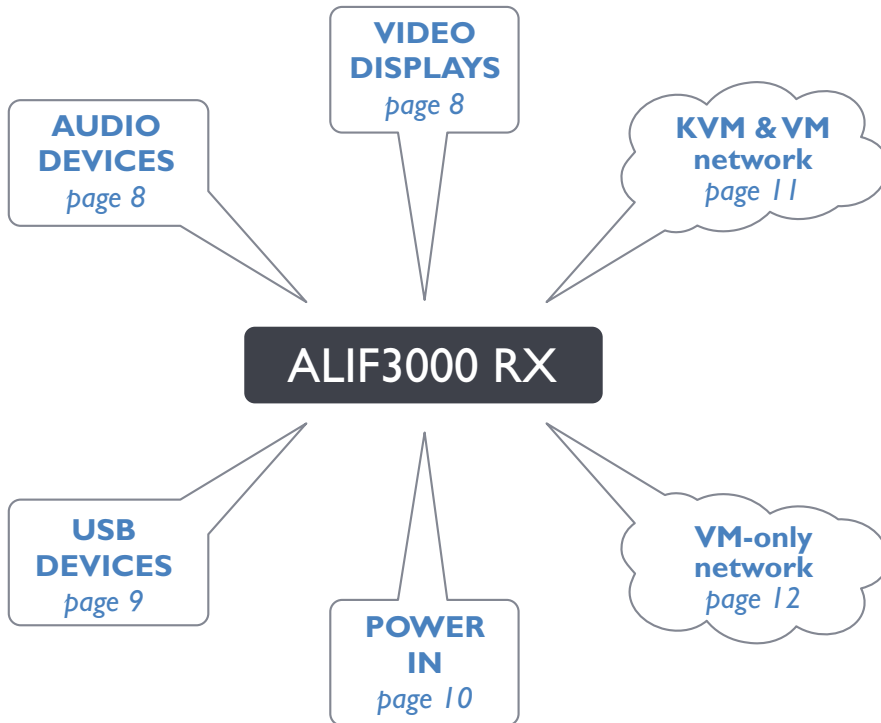

Click a connection to see details

MOUNTING

Please see [Appendix F](#) for details about mounting options for ALIF units.

IMPORTANT: When mounting the ALIF units (and their power adapters), ensure that the vents are not obscured and that there is sufficient airflow. The operating temperature range is 0 to 40°C (0 to 104°F) and must not be exceeded. Each power adapter is rated at a maximum of 68.24BTU/hr.

IMPORTANT: When using an ADDERLink™ INFINITY Management (AIM) server to configure ALIF units, it is vital that all ALIF units that you wish to locate and control are set to their factory default settings. Otherwise they will not be located by the AIM server. If necessary, perform a [factory reset](#) on each ALIF unit.

Please also see [Appendix B - Tips for success when networking ALIF units](#)

Suitable for installation in Information Technology Rooms in accordance with Article 645 of the National Electrical Code and NFPA 75.

Peut être installé dans des salles de matériel de traitement de l'information conformément à l'article 645 du National Electrical Code et à la NFPA 75.

Video displays

The ALIF3000 unit supports two video displays, each up to 1920x1200 or a single display at 2560x1600, with refresh rates up to 60Hz.

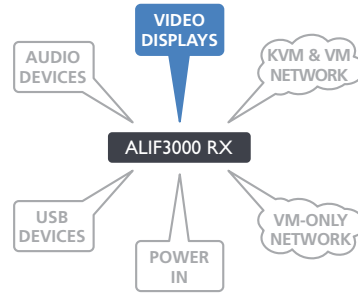

Audio

The ALIF3000 unit can support a microphone as well as speakers and/or headphones.

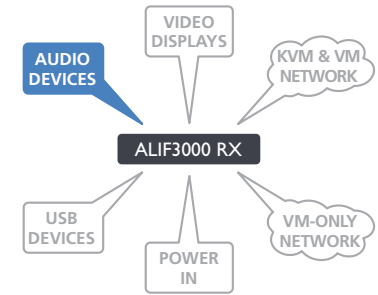

To connect video displays

- 1 Connect the lead from the primary video display to the DisplayPort socket marked '1' on the rear panel:

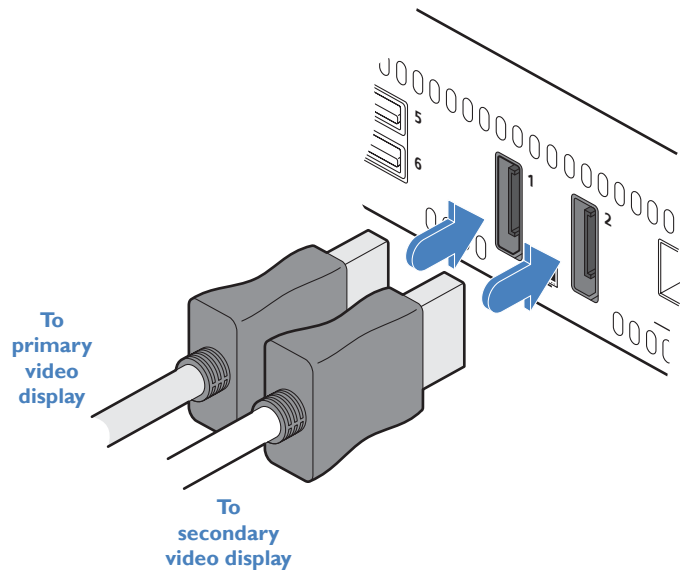

- 2 If required, connect the lead from the second video display to the DisplayPort socket marked '2' on the rear panel.

To connect a microphone, headphones and/or speakers

- 1 Connect the lead from a mono microphone to the 3.5mm socket labeled on the front panel.
- 2 Connect the lead from headphones to the 3.5mm socket labeled on the front panel.
- 3 Connect the lead from stereo speakers to the 3.5mm socket labeled on the front panel.

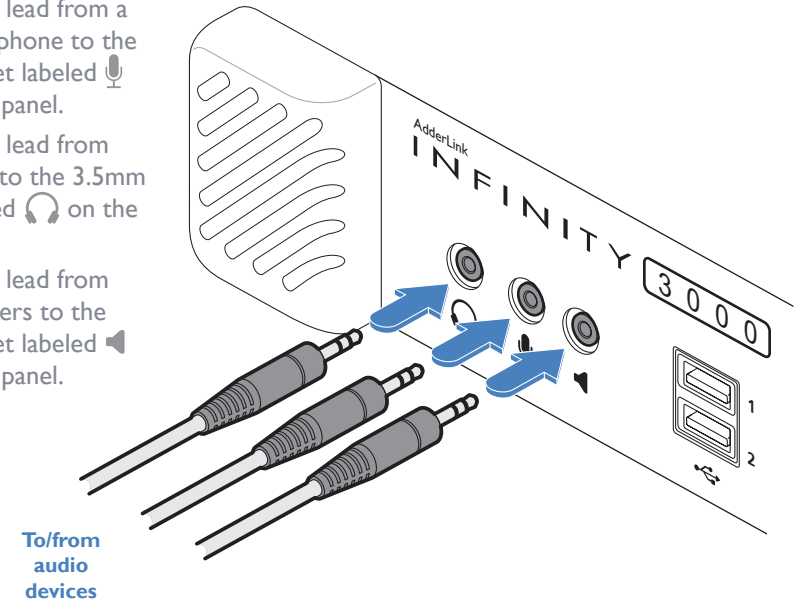

USB devices

The ALIF3000 unit has six USB ports (two on the front panel and four on the rear) to which peripherals may be connected.

To connect more than six peripherals, one or more USB hubs may be used. The total current that may be drawn from the USB ports is 1.2A, which should be sufficient for a keyboard, mouse (no more than 100mA each) and any two other devices (500mA maximum each). If more power for USB devices is required, use a powered USB hub.

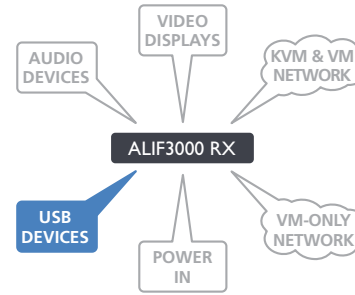

To connect USB devices

1 Connect the lead from the device to any of the USB sockets on the front and rear panels of the unit.

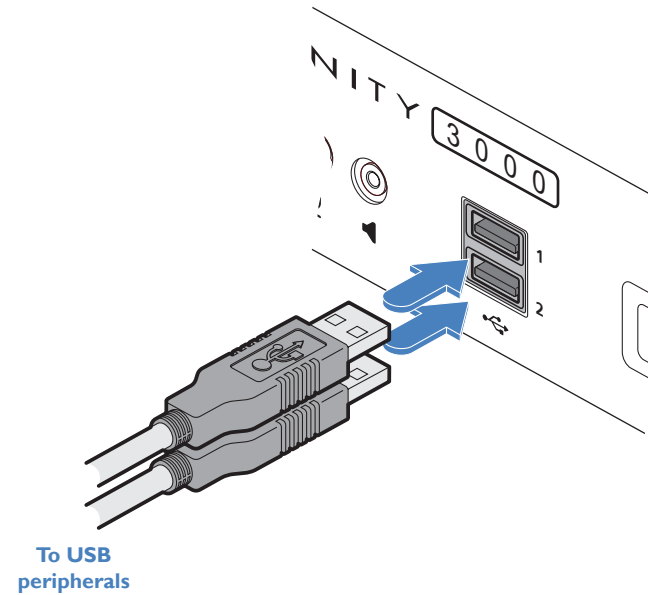
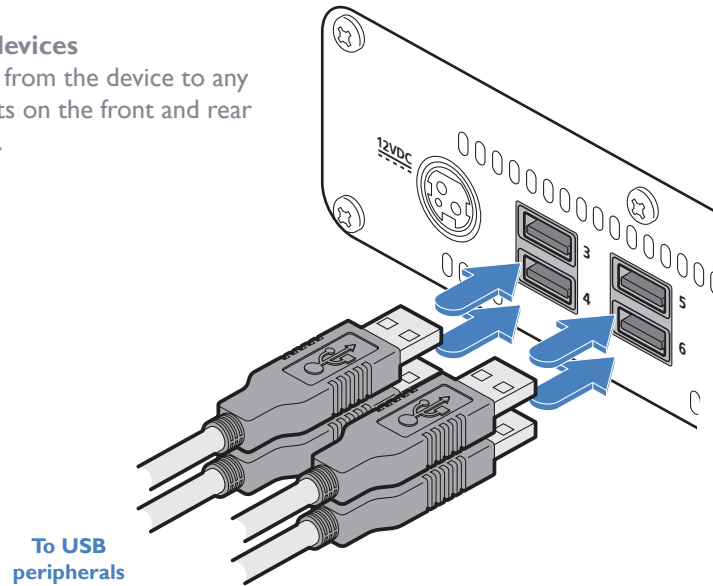

Power in

A power adapter is supplied with a country-specific power cord. The power adapter uses a locking-type plug to help prevent accidental disconnection; please follow the instructions shown on the right when disconnecting a power adapter.

Note: When first powered on and booting up, the indicators and screen of the ALIF3000 unit will not respond for roughly 40 seconds.

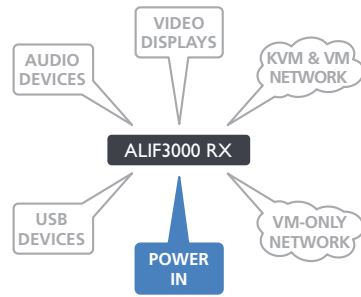

To connect the power adapter

1 Attach the output plug of the supplied power adapter to the power input socket on the left side of the rear panel. As you insert the plug, pull back slightly on the outer body to assist the locking mechanism until the plug is fully inserted.

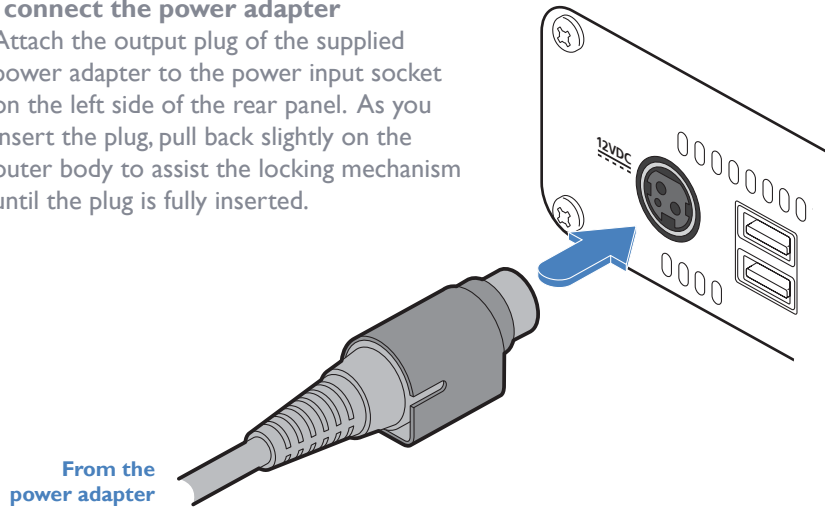

2 Insert the IEC connector of the supplied country-specific power cord to the socket of the power adapter.

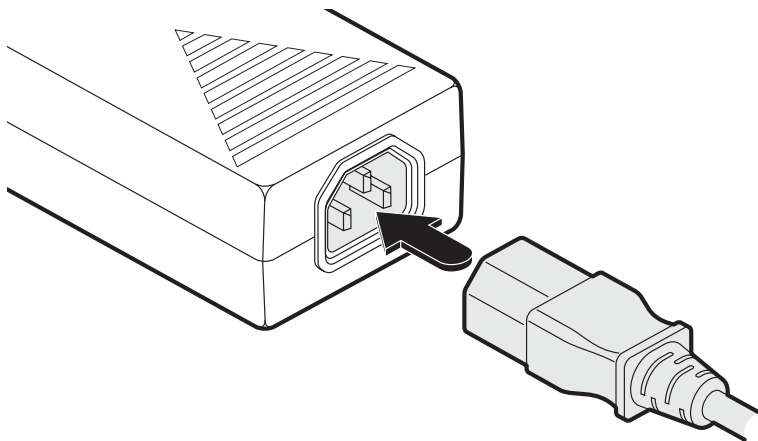

3 Connect the power cord to a nearby mains supply socket.

To disconnect the power adapter

- 1 Isolate the power adapter from the mains supply.
- 2 Grasp the outer body of the power adapter plug where it connects with the node.
- 3 Gently pull the body of the outer plug away from the node. As the body of the plug slides back, it will release from the socket and you can fully withdraw the whole plug.

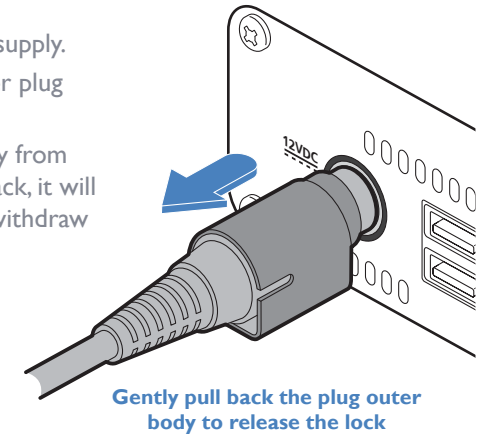

IMPORTANT: Please read and adhere to the electrical safety information given within the Safety information booklet provided with this product. In particular, do not use an unearthed power socket or extension cable.

Note: The unit and the power adapter generate heat when in operation and will become warm to the touch. Do not enclose them or place them in locations where air cannot circulate to cool the equipment. Do not operate the equipment in ambient temperatures exceeding 40 degrees Centigrade. Do not place the products in contact with equipment whose surface temperature exceeds 40 degrees Centigrade.

KVM & VM network links

Two SFP ports are located on the rear panel to allow fiber or copper links to separate networks, according to the type of modules that are inserted.

To create fiber links

- 1 Insert the appropriate optional SFP module (SFP-MM-LC, SFP-SM-LC or SFP-CATX-RJ45) into socket 1 and/or 2 located on the rear panel of the unit:

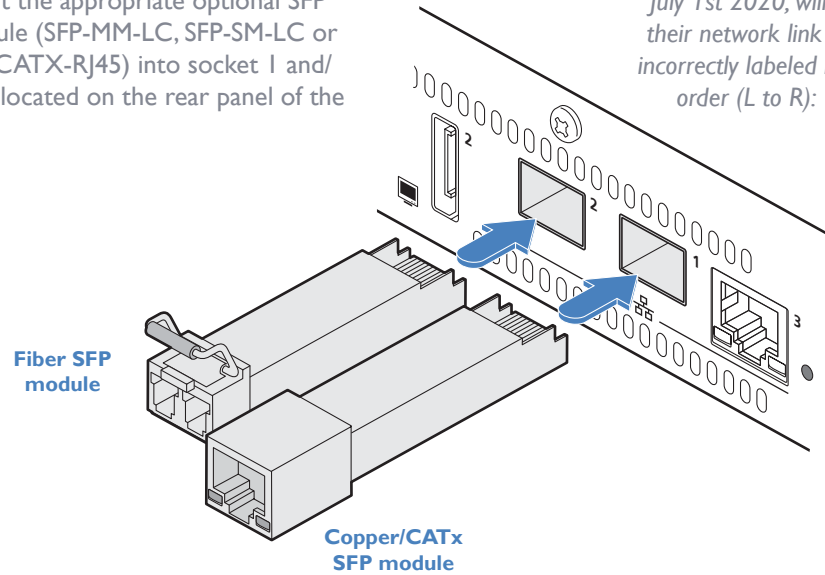

Note: Units shipped before July 1st 2020, will have their network link ports incorrectly labeled in the order (L to R): 1, 2, 3.

*Note: SFP-CATX-RJ45 for use with CAT5e (and above) cable.
SFP-SM-LC modules require OS1 or OS2 single mode fiber.
SFP-MM-LC modules require OM1, OM2, OM3 or OM4 multi-mode fiber.*

See [Appendix E](#) for details.

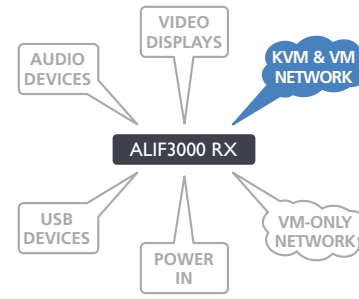

- 2 Make your connection(s) between the chosen SFP module(s) and suitable network switch(es):

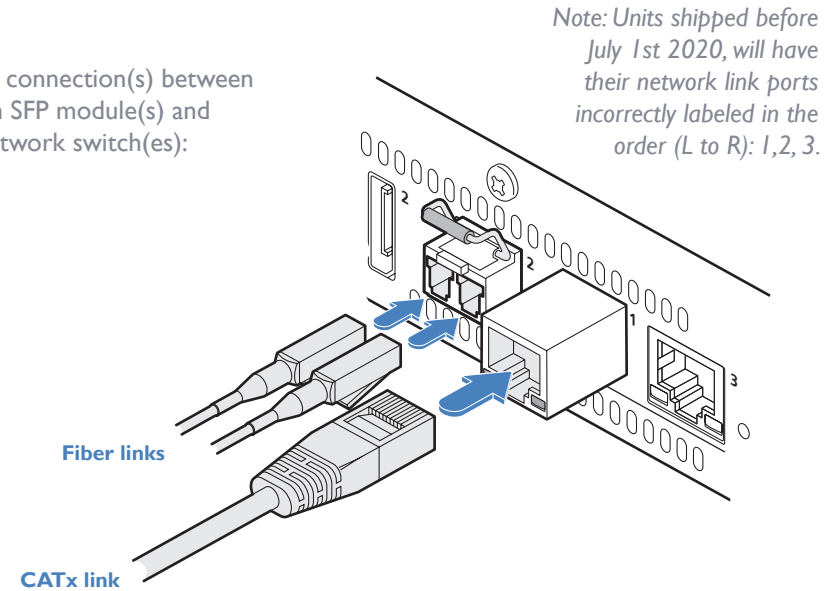

Note: Units shipped before July 1st 2020, will have their network link ports incorrectly labeled in the order (L to R): 1, 2, 3.

- 3 For fiber links, close the latch over the link connectors to lock them into place.

VM-only network link

An RJ45 network socket is located on the rear panel to allow (up to) a 1 Gb CATx copper link to a network.

Note: This port is not supported by AIM and the ALIF3000 is not discoverable by AIM through this port. It is used to access VM machines on a separate network to the KVM network.

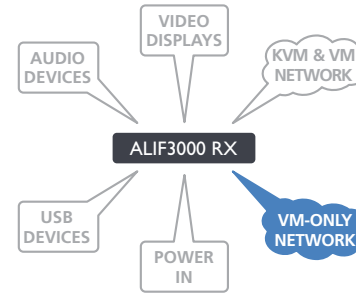

To create a copper link

- 1 Insert a suitable CATx link cable between the RJ45 socket '3' on the rear panel and your network switch.

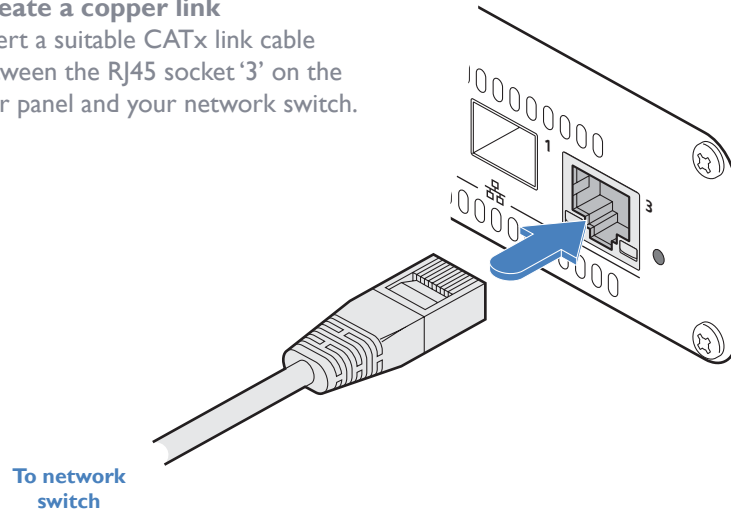

ALIF3000 CONFIGURATION

ALIF3000 units depend upon ADDERLink INFINITY Manager (AIM) for almost all of their configuration. As a new ALIF3000 unit is added to a network it must be in its factory default mode so that AIM can engage with it and begin managing its resources. If an ALIF3000 is not in factory default mode, use the procedure shown right to reset it.

Note: When first powered on and booting up, the indicators and screen of the ALIF3000 unit will not respond for roughly 40 seconds.

AIM configures all ports on the ALIF3000 except for the RJ45 network port (labeled '3') on the rear panel. This port allows connection to a network separate from the main KVM/VM links.

Please refer to:

- **Creating an RDP session** on the [next page](#) in this guide for a walkthrough example,
- The ADDERLink INFINITY Manager user guide (available from adders.com) for details about AIM configuration.

The recessed power button

On the left hand side of the ALIF3000 front panel is a recessed power button which has a couple of uses:

- During a factory reset, this button is used to confirm the action, see right.
- In normal operation, this button can be used to initiate a controlled shut down of the unit. Once shut down in that manner, another press of the button will boot the unit again without having to cycle the power input. *Note: Whenever the unit is first powered on, it will start as normal, it is not necessary to press this button at power on.*

The recessed power button is accessible using a long narrow implement (e.g. a straightened-out paper clip). Its location is similar to the recessed buttons on other ALIF units, however, its function is slightly different.

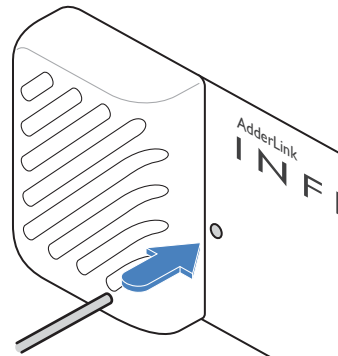

Performing a manual factory reset

A factory reset returns ALIF3000 unit to its default configuration.

To perform a manual factory reset

- 1 Power on the ALIF3000 unit.
- 2 Press-and-hold the button located next to the front panel OLED screen for 10 seconds until the indicator turns blue and the OLED screen shows the message:
In factory reset mode
- 3 You can now either:
 - Return to normal operation without resetting: Press the button next to the OLED screen again.
 - Continue with the factory reset: Use a long narrow implement (e.g. a straightened-out paper clip) to press-and-release the recessed power button on the front panel to power it off. Wait ten seconds and press the button again to power on the unit.
- 4 Once the factory reset has been carried out the unit should now be ready for discovery by an AIM server.

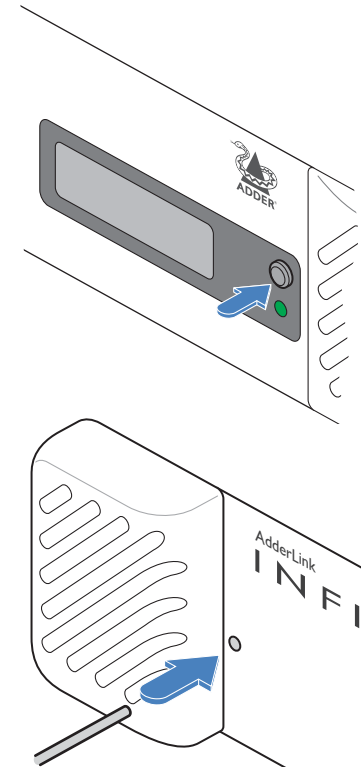

CREATING AN RDP SESSION

This section details the steps required to configure a typical RDP session within ADDERLink INFINITY Manager (AIM). This diagram shows a typical connection layout:

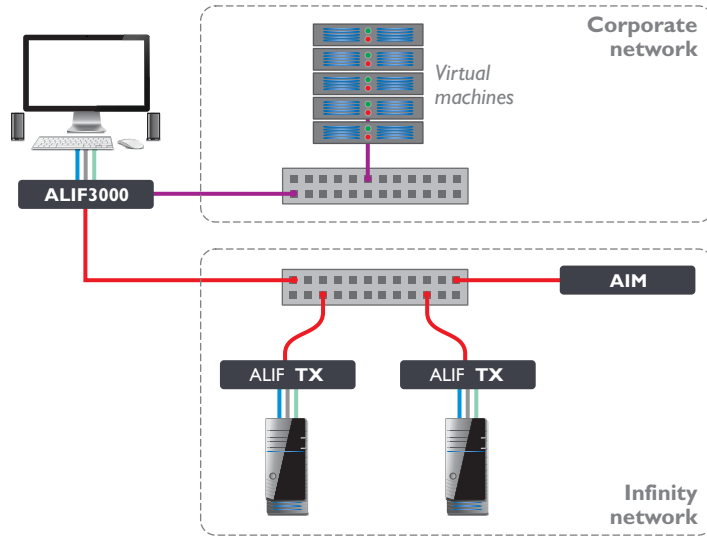

In the sample layout above, the ALIF3000 is connected to two separate networks:

- The **Infinity network** gives access to hosts that are connected via ALIF transmitters,
- The **Corporate network** is where the virtual machines running RDP hosts reside.

Prerequisites

- The AIM Manager is running firmware version 4.11 or above.
- The ALIF3000 is connected to the networks and is recognised by the AIM Manager.
- The Corporate network has a DHCP server to issue the CATx interface its IP address, subnet mask, gateway and DNS settings.

To create an RDP session

- 1 Within the AIM Manager's network interface, navigate to the **Transmitters** page.
- 2 At the top of the page, click on **Add VDI**.

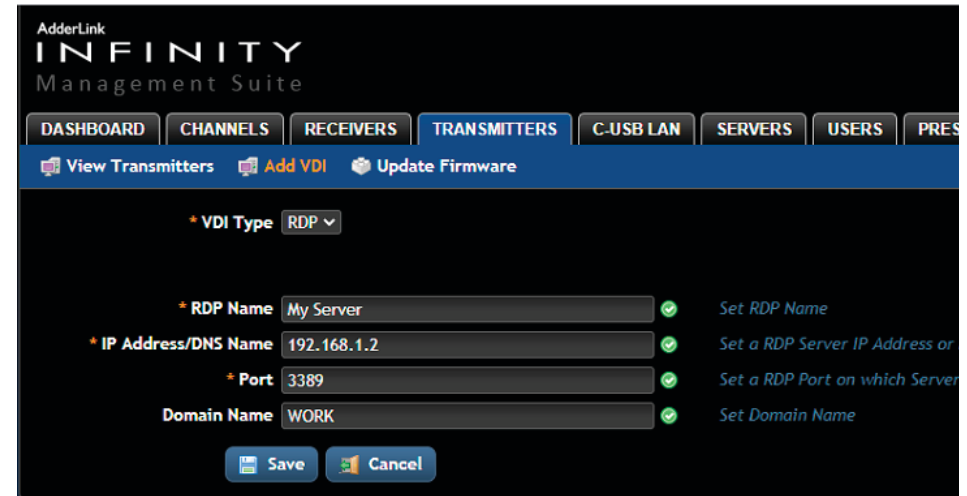

The VDI Type will default to RDP.

- 3 Enter the **RDP Name** for the host.
- 4 Enter the **IP Address** or the **DNS Name** for the RDP host.
- 5 If the RDP Host is part of a Windows domain, enter the **Domain Name** here (this is essential as it cannot be entered during login). Otherwise leave this blank.
- 6 If you are not using the default 3389 port, change the RDP **Port** number.
- 7 Click **Save**. A channel for the transmitter will be generated based on the transmitter's name, in this instance **Channel My Workstation**:

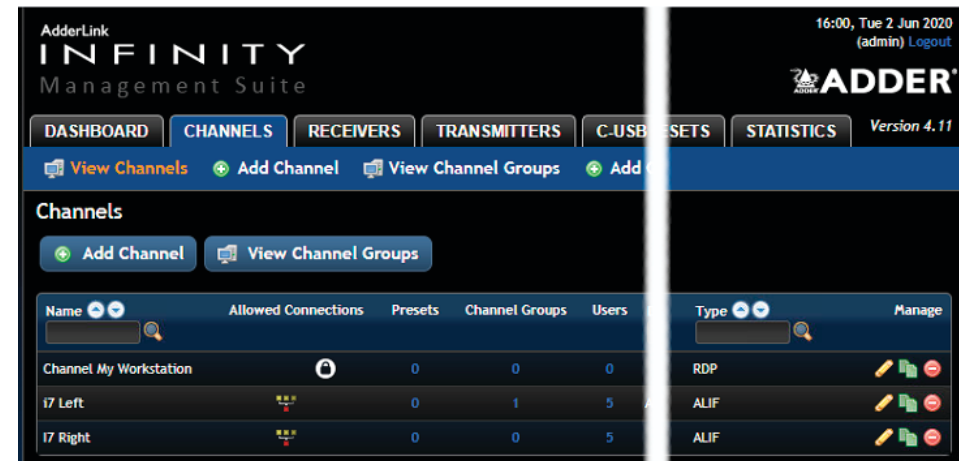

By default, the new channel will have no users or user groups access assigned.

8 Click for the new channel entry to add users who will be granted access to it:

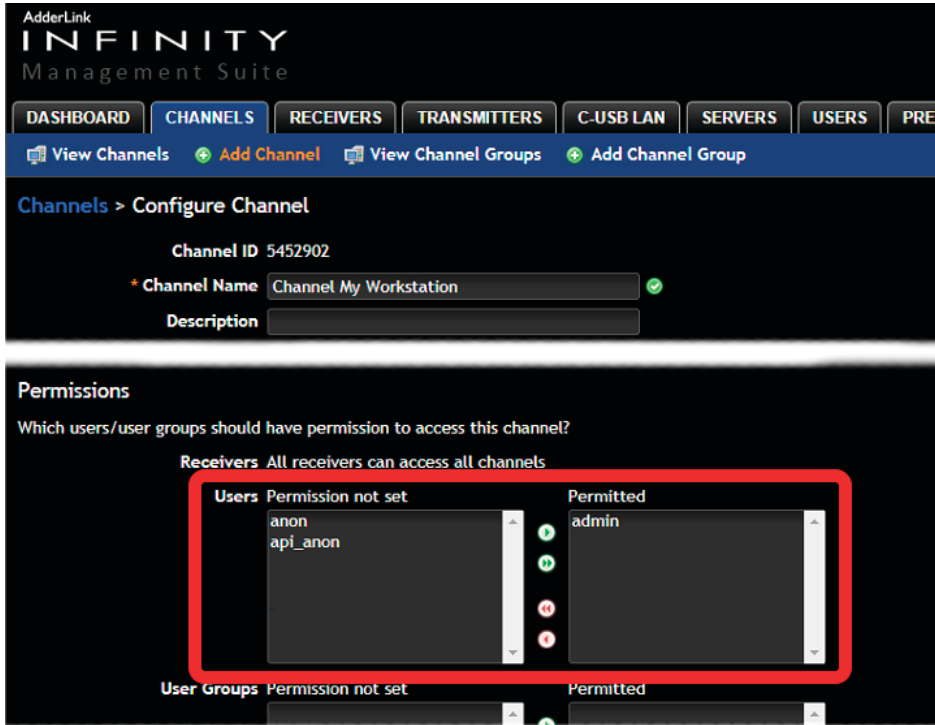

9 On the console attached to the ALIF3000, open the OSD (default CTRL+ALT+C) and log in as a user who has access to the newly created RDP Channel:



You should now see the new RDP channel displayed on the OSD or amongst the pages of other channels and presets. An RDP channel only has two icons, unlike the other channels for standard ALIF transmitters:

- To enter the login credentials for the RDP session.
- To make a private connection to the RDP host.

10 Click on first to enter the user credentials:

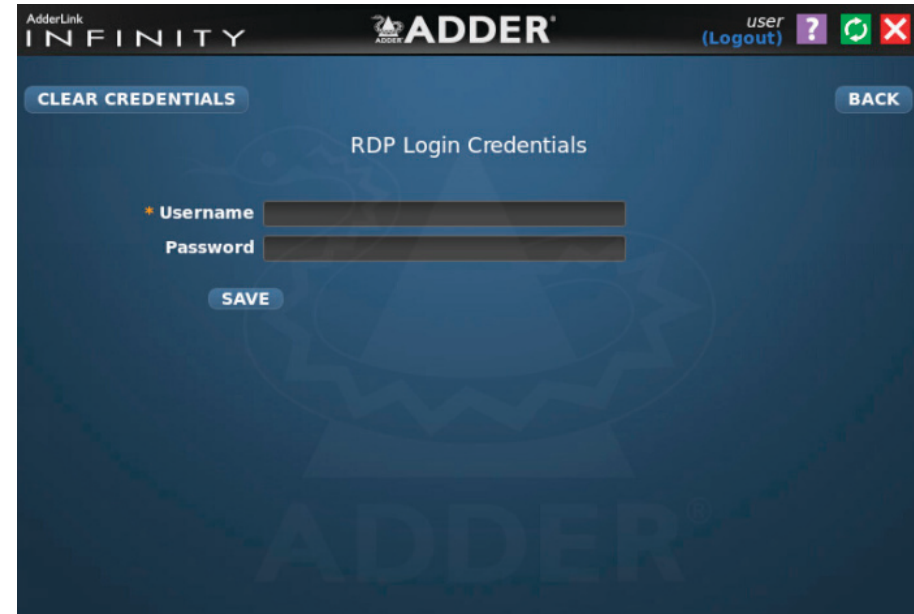

11 Enter the **Username** and **Password** required to access the RDP host.

- Note: Do not use the # or " characters or spaces within passwords.

12 Click Save.

13 Click on to start the RDP session.

In operation, many ALIF3000 installations require no intervention once configured. The unit takes care of all connection control behind the scenes so that you can continue to work unhindered.

OLED SCREEN

- Press and release the button to wake the OLED screen and begin showing information.
- Press the button to advance to the next page.
- If a page is empty e.g there is no alert to show or no IP for an interface, then the page will be skipped.
- Press the button on the last page to return to the first page.



Status page

This primary page will indicate the AIM connection status: Searching..., Connecting.... or Connected.



Connection page

Shows the name of the current channel and also the console peripherals that are connected and operating.



Alert page

If there is an alert, this page will be displayed with an explanation. Once shown, the Status page will be returned.

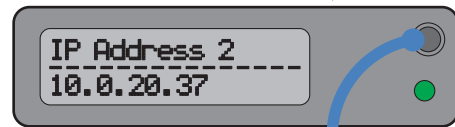

IP Address pages

With each press, the IP addresses of the three network ports will be shown in turn.



AIM Address page

When connection has been made with an AIM server, the server's address will be shown here.

Note: When first powered on and booting up, the indicators and screen of the ALIF3000 unit will not respond for roughly 40 seconds.

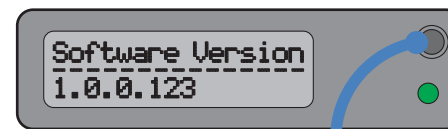

Software version page

Displays the current software version.



Display resolution pages

With each press, the resolutions of the two displays will be shown in turn (if both connected).



MAC Address pages

With each press, the MAC addresses of the three network ports will be shown in turn.



Serial Number page

Shows the serial number of the ALIF3000 unit.

FRONT PANEL INDICATIONS

The front panel of each ALIF3000 unit features a single indicator capable of producing numerous color and flash patterns to provide a useful guide to operation as well as an OLED information screen.

Indicator color and flash patterns

The single front panel indicator uses varying color and flashing patterns to signal key status:

Off	No power.
Green	All services present as compared to the configuration required.
Amber	Running but video, USB or network link missing (or not connected to a transmitter/VM).
Red	Booting before processor loaded or failed.
Blue	Factory reset mode active.
Red/green flash	Booting into factory recovery mode.
Green/blue flash	Upgrade mode active.
Fast green flash	Identify mode active.

This chapter contains a variety of information, including the following:

- Getting assistance - see right
- [Appendix A](#) - Configuration page
- [Appendix B](#) - Tips for success when networking ALIF units
- [Appendix C](#) - Troubleshooting
- [Appendix D](#) - Glossary
- [Appendix E](#) - Fiber modules and cables
- [Appendix F](#) - Using the optional ALIF3000 rack shelf
- [Appendix G](#) - Open source licenses

LITHIUM BATTERY

CAUTION: This product contains a lithium battery which must be disposed of in the correct manner.

CAUTION: RISK OF EXPLOSION IF BATTERY IS REPLACED BY AN INCORRECT TYPE.

- If the lithium battery needs to be changed, you must return the product to your nearest Adder dealer. The battery must be replaced by an authorized Adder dealer.
- Once the product has come to the end of its useful life, the lithium battery must be removed as part of the decommissioning process and recycled in strict accordance with the regulations stipulated by your local authority. Advice on battery removal can be provided on request by Adder.

GETTING ASSISTANCE

If you are still experiencing problems after checking the information contained within this guide, then please refer to the Support section of our website:

www.adder.com

APPENDIX A - Configuration page

The ALIF3000 gains all of its configuration details via AIM; local changes are not possible. Therefore the configuration page mainly provides information only and indicates the settings that have been enacted by the controlling AIM server.

To view the configuration page

1 Using a system connected to the same network as the ALIF3000 unit, open a web browser and access the IP address of the ALIF3000.

- To discover the ALIF3000 unit's main IP address: Press the small button on the front panel next to the OLED screen to reveal the value for IP Address 1 or 2 (depending on which network port(s) are used).

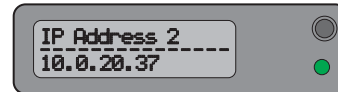

2 The configuration page should be displayed:

ADDERLink
RECEIVER (dual)
ALIF3000

System Information Unit controlled by AIM

About

Identify Unit (short)

Identify Unit (long)

System	Firmware Version
Main	1.0.0.866
Backup	1.0.0.830

Interface	MAC Address	IP Address
Port 1	00:07:32:65:67:63	-
Port 2	00:07:32:65:67:64	10.0.20.37/24
Port 3	00:07:32:65:67:65	10.1.0.160/16

NTP	
Enabled	Yes
Server IP	10.0.10.10

AIM

Identify unit

When clicked, these buttons cause the front panel indicators to flash to assist with identifying the ALIF unit within a rack.

- The **Identify Unit (short)** button flashes the indicators for five seconds.
- The **Identify Unit (long)** button flashes the indicators for one hour but can be overridden by clicking the Identify Unit (short) button.

Remote Support

The ALIF3000 remote support feature allows Adder technical support to connect via a secure SSL connection, should the need arise. When you click the Enable button, the unit will generate and display a single-use password (and port number) on the page. Attach the unit to an internet-connected switch (using a fibre or copper link); note the resulting IP address and pass this, together with the generated password and port number, to Adder technical support, allowing limited direct access.

AIM	
Enabled	Yes
Server IP	10.0.10.10 192.168.10.197 10.0.10.11

DHCP	
Enabled	Yes

Remote Support	
Enabled	No Enable

Hardware Information	
Board Revision	0
System Type	RX8
Product Code	ALIF3000
Unit Serial Number	[NONE]
Unit ID	000732ffe656763
Factory Certificates	e8d8341fc53583fc9e09c23a704ea316

Getting Help

Contact support@adder.com or visit <https://www.adder.com> for help

APPENDIX B - Tips for success when networking ALIF units

ALIF units use multiple strategies to minimize the amount of data that they send across networks. However, data overheads can be quite high, particularly when very high resolution video is being transferred, so it is important to take steps to maximize network efficiency and help minimize data output. The tips given in this section have been proven to produce very beneficial results.

Summary of steps

- Choose the right kind of switch.
- Create an efficient network layout.
- Configure the switches and devices correctly.

Choosing the right switch

[Layer 2](#) switches are what bind all of the hosts together in the subnet. However, they are all not created equally, so choose carefully. In particular look for the following:

- 1 Gigabit ports,
- Support for [IGMP v2](#) (or v3) snooping,
- Support for [Jumbo frames](#) up to 9216-byte size,
- High bandwidth connections between switches, preferably Fiber Channel.
- Look for switches that perform their most onerous tasks (e.g. [IGMP snooping](#)) using multiple dedicated processors (ASICS).
- Ensure the maximum number of concurrent ‘snoopable groups’ the switch can handle meets or exceeds the number of ALIF transmitters that will be used to create multicast groups.
- Check the throughput of the switch: Full duplex, 1Gbps up- and down- stream speeds per port.
- Use the same switch make and model throughout a single subnet.
- You also need a [Layer 3](#) switch. Ensure that it can operate efficiently as an [IGMP Querier](#).

Creating an efficient network layout

Network layout is vital. The use of [IGMP snooping](#) also introduces certain constraints, so take heed:

- Keep it flat. Use a basic line-cascade structure rather than a pyramid or tree arrangement.
- Keep the distances between the switches as short as possible.
- Ensure sufficient bandwidth between switches to eliminate bottlenecks.
- Where the AIM server is used to administer multiple ALIF transceivers, ensure the AIM server and all ALIF units reside in the same subnet.
- Do not use VGA to DisplayPort converters, instead replace VGA video cards in older systems with suitable DisplayPort replacements. Converters cause ALIF TX units to massively increase data output.
- Wherever possible, create a private network.

The recommended layout

The layout shown below has been found to provide the most efficient network layout for rapid throughput when using IGMP snooping:

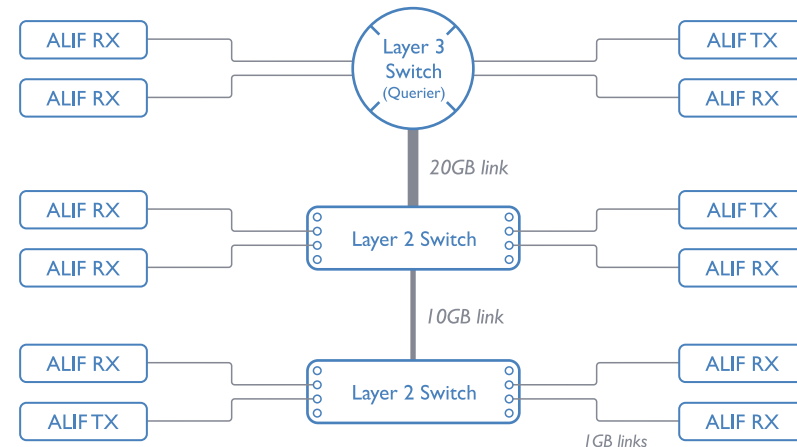

- Use no more than two cascade levels.
- Ensure high bandwidth between the two L2 switches and very high bandwidth between the top L2 and the L3. Typically 10GB and 20GB, respectively for 48 port L2 switches.

continued

Configuring the switches and devices

The layout is vital but so too is the configuration:

- Enable [IGMP Snooping](#) on all L2 switches.
 - Ensure that [IGMP Fast-Leave](#) is enabled on all switches with ALIF units connected directly to them.
 - Enable the L3 switch as an [IGMP Querier](#).
 - Enable [Spanning Tree Protocol \(STP\)](#) on all switches and importantly also enable portfast (only) on all switch ports that have ALIF units connected.
 - If any hosts will use any video resolutions using 2048 horizontal pixels (e.g. 2048 x 1152, 2048 x 2048), ensure that [Jumbo Frames](#) are enabled on all switches.
 - Choose an appropriate forwarding mode on all switches. Use [Cut-through](#) if available, otherwise [Store and forward](#).
 - Optimize the settings on the ALIF transmitters:
 - If moving video images are being shown frequently, then leave Frame Skipping at a low percentage and instead reduce the Peak bandwidth limiter.
 - Where screens are quite static, try increasing the Background Refresh interval and/or increasing the Frame skipping percentage setting.
- Make changes to the ALIF transmitters one at a time, in small steps, and view typical video images so that you can attribute positive or negative results to the appropriate control.
- Ensure that all ALIF units are fully updated to the latest firmware version (at least v2.1).

APPENDIX C - Troubleshooting

Problem: The video image of the ALIF receiver shows horizontal lines across the screen.

This issue is known as *Blinding* because the resulting video image looks as though you're viewing it through a venetian blind.

When video is transmitted by ALIF units, the various lines of each screen are divided up and transmitted as separate data packets. If the reception of those packets is disturbed, then blinding is caused. The lines are displayed in place of the missing video data packets.

There are several possible causes for the loss of data packets:

- Incorrect switch configuration. The problem could be caused by multicast flooding, which causes unnecessary network traffic. This is what IGMP snooping is designed to combat, however, there can be numerous causes of the flooding.
- Speed/memory bandwidth issues within one or more switches. The speed and capabilities of different switch models varies greatly. If a switch cannot maintain pace with the quantity of data being sent through it, then it will inevitably start dropping packets.
- One or more ALIF units may be outputting Jumbo frames due to the video resolution (2048 horizontal pixels) being used. If Jumbo frames are output by an ALIF unit, but the network switches have not been configured to use jumbo frames, the switches will attempt to break the large packets down into standard packets. This process introduces a certain latency and could be a cause for dropped packets.
- One or more ALIF units may be using an old firmware version. Firmware versions prior to v2.1 exhibited an issue with the timing of IGMP join and leave commands that caused multicast flooding in certain configurations.

Remedies:

- Ensure that [IGMP snooping](#) is enabled on all switches within the subnet.
- Where each ALIF unit is connected as the sole device on a port connection to a switch, enable [IGMP Fast-Leave \(aka Immediate Leave\)](#) to reduce unnecessary processing on each switch.
- Check the video resolution(s) being fed into the ALIF transmitters. If resolutions using 2048 horizontal pixels are unavoidable then ensure that [Jumbo frames](#) are enabled on all switches.
- Check the [forwarding mode](#) on the switches. If *Store and forward* is being used, try selecting *Cut-through* as this mode causes reduced latency on lesser switch designs.
- Ensure that one device within the subnet is correctly configured as an [IGMP Querier](#), usually a layer 3 switch or multicast router.
- Ensure that the firmware in every ALIF unit is version 2.1 or greater.
- Try adjusting the transmitter settings on each ALIF to make the output data stream as efficient as possible. See [ALIF transmitter video settings](#) for details.

continued

Problem:The audio output of the ALIF receiver sounds like a scratched record.

This issue is called Audio crackle and is a symptom of the same problem that produces blinding (see previous page).The issue is related to missing data packets.

Remedies:

As per blinding discussed previously.

Problem:AIM cannot locate working ALIF units.

There are a few possible causes:

- The ALIF units must be reset back to their zero config IP addresses for AIM discovery. If you have a working network of ALIF's without AIM and then add AIM to the network, AIM will not discover the ALIFs until they are reset to the zero config IP addresses.
- This could be caused by Layer 2 Cisco switches that have [Spanning Tree Protocol \(STP\)](#) enabled but do not also have *portfast* enabled on the ports to which ALIF units are connected. Without portfast enabled,ALIF units will all be assigned the same zero config IP address at reboot and AIM will only acquire them one at a time on a random basis.

You can easily tell whether portfast is enabled on a switch that is running STP: When you plug the link cable from a working ALIF unit into the switch port, check how long it takes for the port indicator to change from orange to green. If it takes roughly one second, portfast is on; if it takes roughly thirty seconds then portfast is disabled.

Remedies:

- Ensure that the ALIF units and the AIM server are located within the same subnet because AIM cannot cross subnet boundaries.
- [Manually reset](#) the ALIF units to their zero config IP addresses.
- Enable portfast on all switch ports that have ALIF units attached to them or try temporarily disabling STP on the switches while AIM is attempting to locate ALIF units.

APPENDIX D - Glossary

Internet Group Management Protocol

Where an ALIF transmitter is required to stream video to two or more receivers, multicasting is the method used.

Multicasting involves the delivery of identical data to multiple receivers simultaneously without the need to maintain individual links. When multicast data packets enter a subnet, the natural reaction of the switches that bind all the hosts together within the subnet, is to spread the multicast data to all of their ports. This is referred to as Multicast flooding and means that the hosts (or at least their network interfaces) are required to process plenty of data that they didn't request. IGMP offers a partial solution.

The Internet Group Management Protocol (IGMP) is designed to prevent multicast flooding by allowing [Layer 3](#) switches to check whether host computers within their care are interested in receiving particular multicast transmissions. They can then direct multicast data only to those points that require it and can shut off a multicast stream if the subnet has no recipients.

There are currently three IGMP versions: 1, 2 and 3, with each version building upon the capabilities of the previous one:

- IGMPv1 allows host computers to opt into a multicast transmission using a Join Group message, it is then incumbent on the router to discover when they no longer wish to receive; this is achieved by polling them (see IGMP Querier below) until they no longer respond.
- IGMPv2 includes the means for hosts to opt out as well as in, using a Leave Group message.
- IGMPv3 encompasses the abilities of versions 1 and 2 but also adds the ability for hosts to specify particular sources of multicast data.

ADDERLink™ INFINITY units make use of IGMPv2 when performing multicasts to ensure that no unnecessary congestion is caused.

IGMP Snooping

The IGMP messages are effective but only operate at [layer 2](#) - intended for routers to determine whether multicast data should enter a subnet. A relatively recent development has taken place within the switches that glue together all of the hosts within each subnet: IGMP Snooping. IGMP snooping means these layer 2 devices now have the ability to take a peek at the IGMP messages. As a result, the switches can then determine exactly which of their own hosts have requested to receive a multicast – and only pass on multicast data to those hosts.

IGMP Querier

When IGMP is used, each subnet requires one [Layer 3](#) switch to act as a Querier. In this lead role, the switch periodically sends out IGMP Query messages and in response all hosts report which multicast streams they wish to receive. The Querier device and all snooping Layer 2 switches then update their lists accordingly (the lists are also updated when Join Group and Leave Group (IGMPv2) messages are received).

IGMP Fast-Leave (aka Immediate Leave)

When a device/host no longer wishes to receive a multicast transmission, it can issue an IGMP Leave Group message as mentioned above. This causes the switch to issue an IGMP Group-Specific Query message on the port (that the Leave Group was received on) to check no other receivers exist on that connection that wish to remain a part of the multicast. This process has a cost in terms of switch processor activity and time.

Where ALIF units are connected directly to the switch (with no other devices on the same port) then enabling IGMP Fast-Leave mode means that switches can immediately remove receivers without going through a full checking procedure. Where multiple units are regularly joining and leaving multicasts, this can speed up performance considerably.

Jumbo frames (Jumbo packets)

Since its commercial introduction in 1980, the Ethernet standard has been successfully extended and adapted to keep pace with the ever improving capabilities of computer systems. The achievable data rates, for instance, have risen in ten-fold leaps from the original 10Mbit/s to a current maximum of 100Gbit/s.

While data speeds have increased massively, the standard defining the number of bytes (known as the Payload) placed into each data packet has remained resolutely stuck at its original level of 1500 bytes. This standard was set during the original speed era (10Mbits/s) and offered the best compromise at that speed between the time taken to process each packet and the time required to resend faulty packets due to transmission errors.

But now networks are much faster and files/data streams are much larger; so time for a change? Unfortunately, a wholesale change to the packet size is not straightforward as it is a fundamental standard and changing it would mean a loss of backward compatibility with older systems.

Larger payload options have been around for a while, however, they have often been vendor specific and at present they remain outside the official standard. There is, however, increased consensus on an optional 'Jumbo' payload size of 9000 bytes and this is fully supported by the ADDERLink™ INFINITY (ALIF) units.

Jumbo frames (or Jumbo packets) offer advantages for ALIF units when transmitting certain high resolution video signals across a network. This is because the increased data in each packet reduces the number of packets that need to be transferred and dealt with - thus reducing latency times.

The main problem is that for jumbo frames to be possible on a network, all of the devices on the network must support them.

Spanning Tree Protocol (STP)

In order to build a robust network, it is necessary to include certain levels of redundancy within the interconnections between switches. This will help to ensure that a failure of one link does not lead to a complete failure of the whole network.

The danger of multiple links is that data packets, especially multicast packets, become involved in continual loops as neighbouring switches use the duplicated links to send and resend them to each other.

To prevent such bridging loops from occurring, the Spanning Tree Protocol (STP), operating at [layer 2](#), is used within each switch. STP encourages all switches to communicate and learn about each other. It prevents bridging loops by blocking newly discovered links until it can discover the nature of the link: is it a new host or a new switch?

The problem with this is that the discovery process can take up to 50 seconds before the block is lifted, causing problematic timeouts.

The answer to this issue is to enable the portfast variable for all host links on a switch. This will cause any new connection to go immediately into forwarding mode. However, take particular care not to enable portfast on any switch to switch connections as this will result in bridging loops.

Forwarding modes

In essence, the job of a layer 2 switch is to transfer as fast as possible, data packets arriving at one port out to another port as determined by the destination address. This is known as data forwarding and most switches offer a choice of methods to achieve this. Choosing the most appropriate forwarding method can often have a sizeable impact on the overall speed of switching:

- **Store and forward** is the original method and requires the switch to save each entire data packet to buffer memory, run an error check and then forward if no error is found (or otherwise discard it).
- **Cut-through** was developed to address the latency issues suffered by some store and forward switches. The switch begins interpreting each data packet as it arrives. Once the initial addressing information has been read, the switch immediately begins forwarding the data packet while the remainder is still arriving. Once all of the packet has been received, an error check is performed and, if necessary, the packet is tagged as being in error. This checking 'on-the-fly' means that cut-through switches cannot discard faulty packets themselves. However, on receipt of the marked packet, a host will carry out the discard process.
- **Fragment-free** is a hybrid of the above two methods. It waits until the first 64 bits have been received before beginning to forward each data packet. This way the switch is more likely to locate and discard faulty packets that are fragmented due to collisions with other data packets.
- **Adaptive** switches automatically choose between the above methods. Usually they start out as a cut-through switches and change to store and forward or fragment-free methods if large number of errors or collisions are detected.

So which one to choose? The *Cut-through* method has the least latency so is usually the best to use with ADDERLink™ INFINITY units. However, if the network components and/or cabling generate a lot of errors, the *Store and forward* method should probably be used. On higher end store and forward switches, latency is rarely an issue.

Layer 2 and Layer 3: The OSI model

When discussing network switches, the terms Layer 2 and Layer 3 are very often used. These refer to parts of the Open System Interconnection (OSI) model, a standardized way to categorize the necessary functions of any standard network.

There are seven layers in the OSI model and these define the steps needed to get the data created by you (imagine that you are Layer 8) reliably down onto the transmission medium (the cable, optical fiber, radio wave, etc.) that carries the data to another user; to complete the picture, consider the transmission medium is Layer 0. In general, think of the functions carried out by the layers at the top as being complex, becoming less complex as you go lower down.

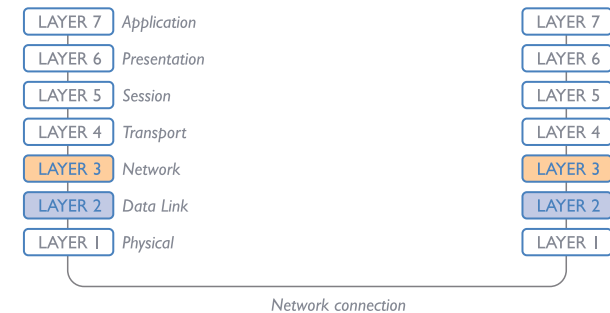

As your data travel down from you towards the transmission medium (the cable), they are successively encapsulated at each layer within a new wrapper (along with a few instructions), ready for transport. Once transmission has been made to the intended destination, the reverse occurs: Each wrapper is stripped away and the instructions examined until finally only the original data are left.

So why are Layer 2 and Layer 3 of particular importance when discussing ADDERLink™ INFINITY? Because the successful transmission of data relies upon fast and reliable passage through network switches – and most of these operate at either Layer 2 or Layer 3.

The job of any network switch is to receive each incoming network packet, strip away only the first few wrappers to discover the intended destination then rewrap the packet and send it in the correct direction.

In simplified terms, the wrapper that is added at Layer 2 (by the sending system) includes the physical address of the intended recipient system, i.e. the unique MAC address (for example, 09:f8:33:d7:66:12) that is assigned to every networking device at manufacture. Deciphering recipients at this level is more straightforward than at Layer 3, where the address of the recipient is represented by a logical IP address (e.g. 192.168.0.10) and requires greater knowledge of the surrounding network structure. Due to their more complex circuitry, Layer 3 switches are more expensive than Layer 2 switches of a similar build quality and are used more sparingly within installations.

APPENDIX E - Fiber/copper modules and cables

To suit your installation layout, fiber and copper modules are available for the ALIF3000 units to support various fiber optic and CATx cables. The specifications for all are summarized in this table:

Name	Fiber size	Type	Coding		Distance at 1Gbps	Adder part number for SFP module
			Normal applications	Suggested print nomenclature		
OM1	(62.5/125)	Multimode (TIA-492AAAA)	Orange	62.5/125	220m	SFP-MM-LC
OM2	(50/125)	Multimode (TIA-492AAAB)	Orange	50/125	550m	“
OM3	(50/125)	Multimode (850 nm Laser-optimized) (TIA-492AAAC)	Aqua	850 LO 50 /125	550m	“
OM4	(50/125)	Multimode (850 nm Laser-optimized) (TIA-492AAAC)	Aqua	850 LO 50 /125	550m	“
OS1 and OS2	(9/125)	Single-mode (TIA-492C000 / TIA-492E000)	Yellow	SM/NZDS, SM	10Km	SFP-SM-LC
CATx	n/a	CAT5e and above	n/a	n/a	100m	SFP-CATX-RJ45

APPENDIX F - Using the optional ALIF3000 rack shelf

- 1 Install the empty ALIF3000 rack mount tray into your 19" rack frame and fully secure it.
- 2 Place an ALIF3000 unit into each side of the rack mount tray so that their rear panels butt up against the small pegs located on each of the side walls.
- 3 Locate the supplied thumbscrew and spacer.
- 4 Insert the thumbscrew through the spacer; then insert into the small hole at the end of the center divider (A).
- 5 Gently tighten the thumbscrew so that the spacer engages with the inner edges of the two ALIF3000 units and holds them in place (B).
- 6 Place the power adapters in the rear section of the rack mount tray and connect them to their respective ALIF3000 units.
- 7 Make all other necessary connections to the ALIF3000 units.

IMPORTANT: When mounting the ALIF units (and their power adapters), ensure that the vents are not obscured and that there is sufficient airflow. The operating temperature range is 0 to 40°C (0 to 104°F) and must not be exceeded. Each power adapter is rated at a maximum of 68.24BTU/hr.

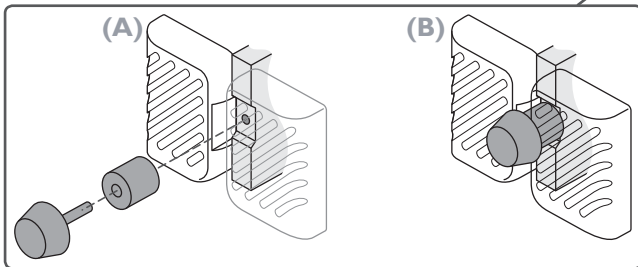
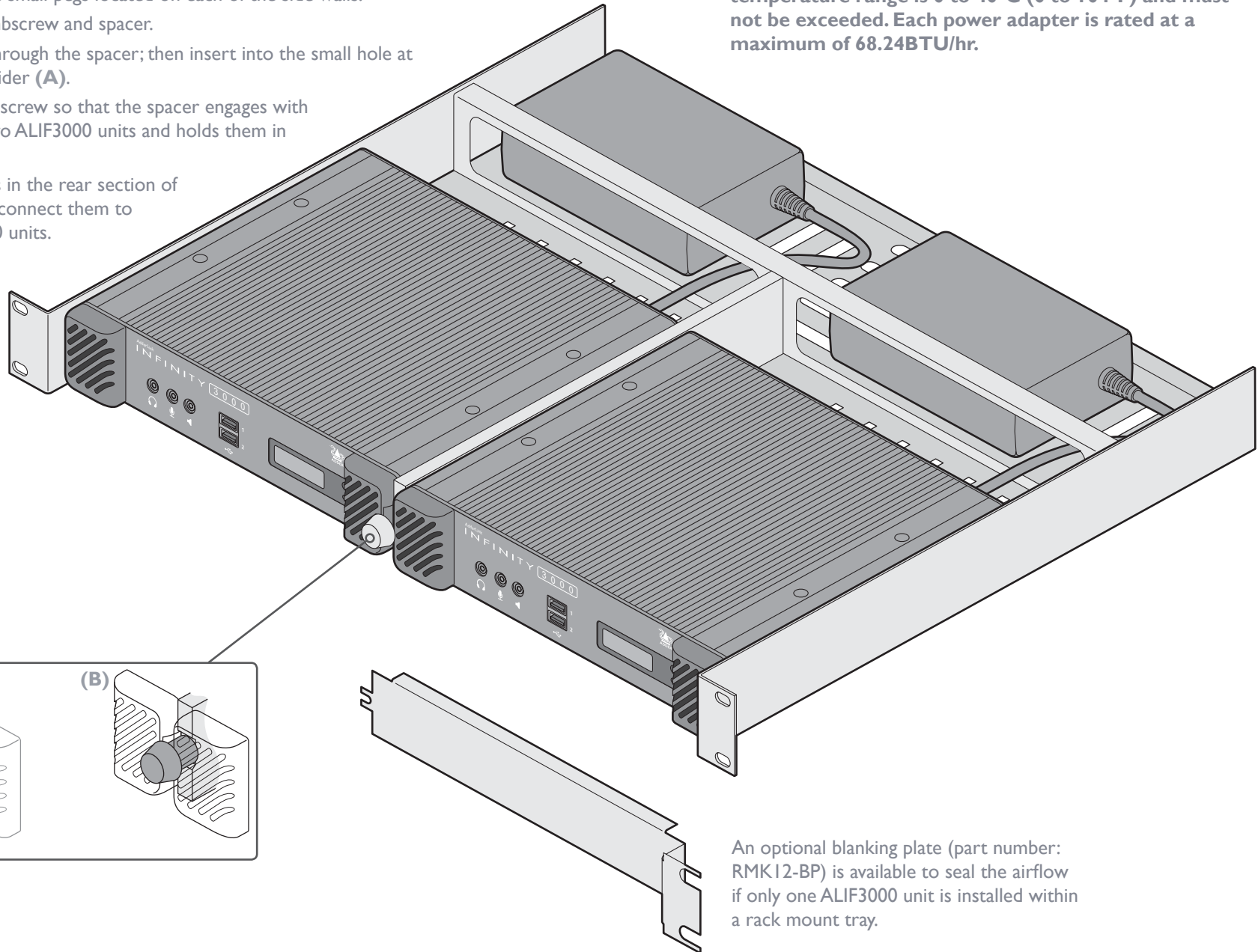

An optional blanking plate (part number: RMK12-BP) is available to seal the airflow if only one ALIF3000 unit is installed within a rack mount tray.

APPENDIX G - OPEN SOURCE LICENSES

This product includes binaries that are derived from the open source community by Adder under the GNU General Public License v2. Please follow the link below to view the full list of open source licenses used:

<http://support.adder.com/tiki/tiki-index.php?page=ALIF3000%3A+OpenSource+Licence>

The software included in this product contains copyrighted software that is licensed under the GNU General Public License (GPL). You may obtain the complete Corresponding Source Code from Adder for a period of three years after the last shipment of this product, which will be no earlier than 2028, by contacting support@adder.com or writing to:

Attn: ACD/Open Source Request,
Adder Technology Ltd,
Saxon Way, Bar Hill,
Cambridge, CB23 8SL,
United Kingdom

Please write “Source for product XXXXXXXXX” in the subject line, where XXXXXXXXX is the model and version number.

This offer is valid to anyone in receipt of this information.



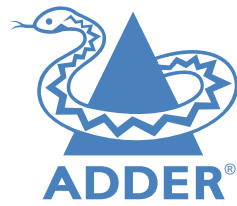

www.adder.com

Documentation by:



www.ctxd.com

© 2020 Adder Technology Limited
All trademarks are acknowledged.
Part No. MAN-ALIF3000-ADDER • Release 1.2

A

Adaptive 25
AIM 14
Audio 8

C

Configuration
 AIM 13
 page 19
Connections
 overview 7
Cut-through 25

F

Factory reset 13
Fast-Leave 24
Forwarding modes 25
Fragment-free 25
Front panel indicators 16

I

Identify unit 19
IGMP 24
 fast-leave 24
 querier 24
 snooping 24
Indicators 17

J

Jumbo frames (packets) 24

L

Layers 2 and 3 25
Lithium battery 18

M

MAC Address 16
Mounting 7

N

Network layout 20
Network links 11
 KVM & VM 11
 VM-only 12
Network switch
 choosing 20

O

OLED screen 16
OSI model 25

P

Power in 10

Q

Querier 24

R

RDP session 14
Remote Support 19
Reset 13

S

Serial Number 16
SFP ports 11
Snooping 24
Software version 16
Spanning Tree Protocol 25
Status page 16
Store and forward 25
Switch
 choosing 20
 configuring 21

T

Technical specifications 3
Troubleshooting 18,22

U

USB connections 9

V

VDI 2,14
Video displays 8